

**Armstrong
Piston Valves**
The Ideal
Isolation Valve



Armstrong®



Armstrong® Armstrong Piston Valves

Description

Armstrong Piston Valves are full port forged steel isolation valves with a maximum operating pressure of 136 Barg/1973 psig and a maximum operating temperature of 427°C/800°F. The burnished piston and metal reinforced graphite rings provide leak-proof shut off and allow Armstrong Piston Valves to be operated at higher temperatures, while also extending operating life.

Armstrong Piston Valves are available in Socket Weld, BSPT, and NPT end connections. Flanged ends can be supplied upon request.

Armstrong Piston Valves are ideal for saturated and superheated steam, and hot water applications.

Armstrong Piston Valves Feature:

- Leak-proof isolation
- Sizes from 15mm/1/2" NB to 40mm/1-1/2" NB
- Choice of socket weld, screwed or flanged end connections
- Compatible with API, ASME, IBR, and DIN standards
- Resistant to cavitation
- All sealing valve components may be easily replaced in-line
- Long-term operation. Piston valve design ensures actuation even after many years without operation
- Fire-proof performance

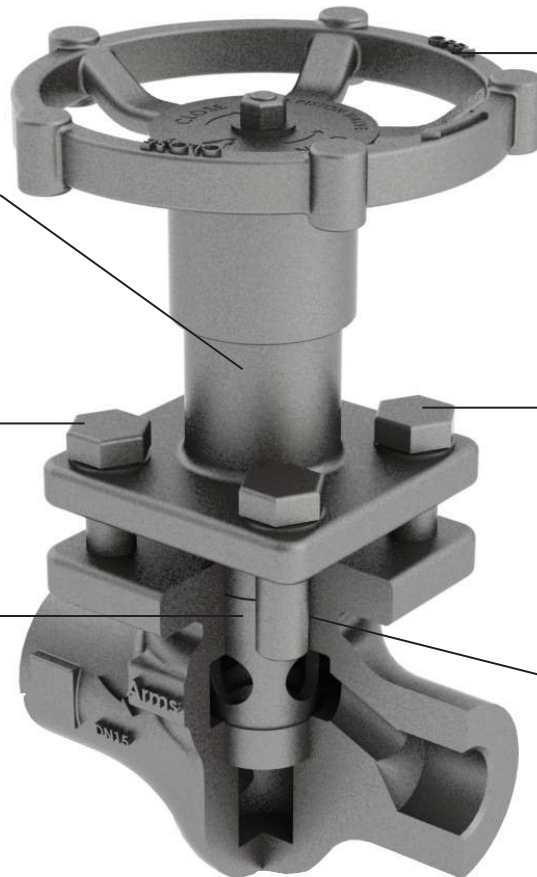

Ductile Iron hand wheel designed for easy operation.

Piston stem is fully enclosed to prevent dirt and corrosion.

Four-bolt mechanism with Belleville washers to ensure spring action even in high temperature applications.

ASTM A19 GR B7 bolts for high temperature operation.

Precision burnished stainless steel pistons provide long-term operation, and ensures actuation even after many years without operation. The piston slides without rotating between the two valve sealing rings, preventing dirt from damaging the surfaces.

Flexible graphite reinforced ring stacks that withstand high temperatures and feature superior mechanical bonding.

Armstrong Piston Valves

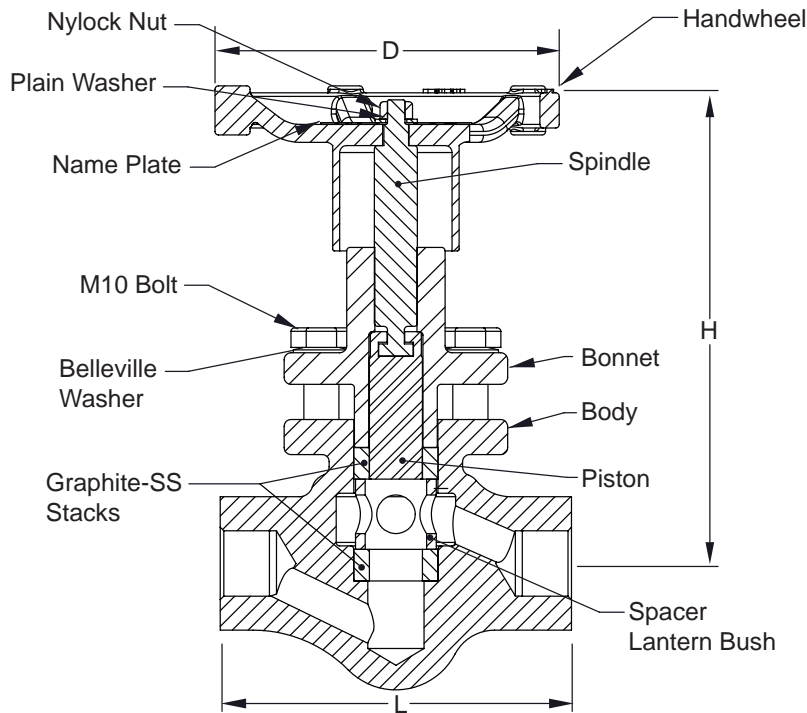

Forged Piston Valves ANSI Class 800 (API602 & ASME B16.34)											
NB/DN	Body Material	L		H		D		Minimum Thread	Bolting Type	Approximate Weight	
		mm	in	mm	in	mm	in			kg	lbs
15	A105/LF2	100	3.9	134	5.3	93	3.7	14	4B - SE/SW	1.9	4.2
20	A105/LF2	120	4.7	138.5	5.5	93	3.7	14	4B - SE/SW	3.4	7.5
25	A105/LF2	135	5.3	183	7.2	112	4.4	18	4B - SE/SW	4.8	10.6
40	A105/LF2	185	7.3	226	8.9	112	4.4	19	4B - SE/SW	11.5	25.4

Design Features Forged Steel Piston Valves Class 800 (Sizes 15, 20, 25, 40NB)									
End Connections *	Maximum Pressure at Temperature				Maximum Temperature at Operating Pressure				Hydro Test Pressure at Ambient Temperature
	barg	°C	psig	°F	°C	barg	°F	psig	
Socketweld ends	136.20	≤38	1975.41	100	427	75.84	801	1099.97	204.30

* Other end connections may have restricted pressure and temperature ratings due to applicable standards.

Design features of Armstrong Piston Valves:

Material of Construction - Body

- Forged Steel (ASTM A105, ASTM A350 LF2)

Material of Construction – Graphite Ring Stack

- Flexible Graphite and SS 316

Design Standards

- ASME (B16.34, B16.10, B16.5)
- API (600, 602)
- IBR 1950
- DIN (3202, 10226-1)
- Inspection and testing (API 598)
- Leak test (ANSI/FCI 70-2)
- Fire test (API SPEC 6FA : 1999)

Armstrong provides intelligent system solutions that improve utility performance, lower energy consumption, and reduce environmental emissions while providing an “enjoyable experience.”



Armstrong International
North America • Latin America • India • Europe / Middle East / Africa • China • Pacific Rim

armstronginternational.in

Bulletin 191
6/12

© 2012 Armstrong International, Inc.