

Steam QM-1

Steam Quality Monitor

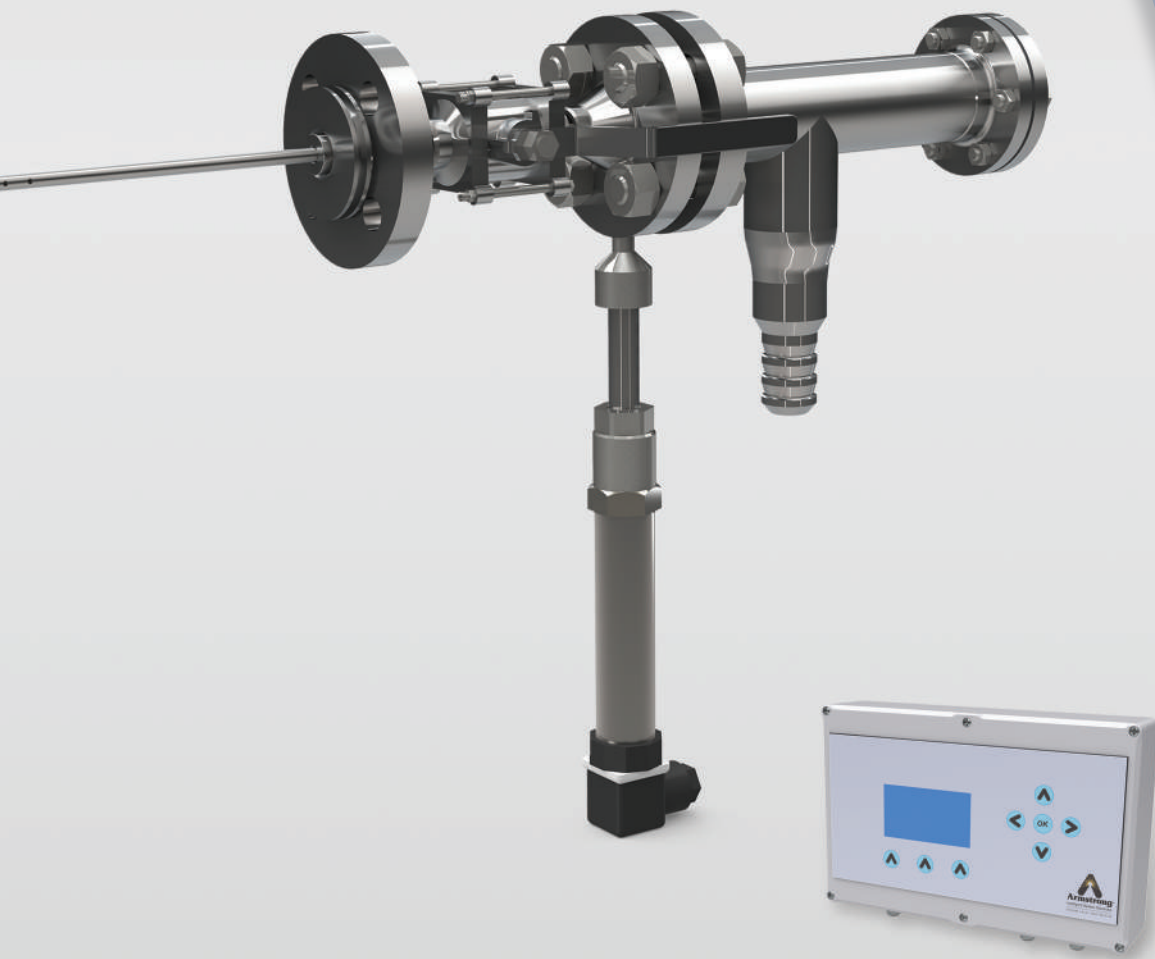



# Steam Quality Monitor – Steam QM-1

Until now measuring steam dryness fraction has largely been a manual process, which is time consuming and presents inherent safety and accuracy risks.

Steam QM-1 is an automatic steam quality monitor that safely and reliably determines and communicates the dryness fraction of plant and culinary steam; allowing you to continuously and efficiently monitor your steam system.



## Product Features

- Simple installation
- Reliable/repeatable accuracy
- Steam dryness monitoring
- Safe alternative to the traditional manual method of sampling steam
- RS485 connection for data logging using regulation compliant device; results may be remotely monitored via MODBUS
- All stainless steel construction

## Why measure steam dryness?

- Manage process quality when injecting steam
- Ensure food grade quality of steam (e.g. culinary steam)
- Check dryness of outsourced steam
- Avoid water hammer
- Oversee traps and separators effectiveness
- Monitor boiler carry over
- Avoid erosion in valves, regulators, etc.
- Control the desuperheater (X used instead of P and T)
- Protect turbine LP saturated steam stages
- Correct flow meter values

Steam QM-1 Specifications	
Steam Operating Pressure Range	43-465 psig (3-32 barg)
Voltage	12 VAC or 15 - 24 VDC

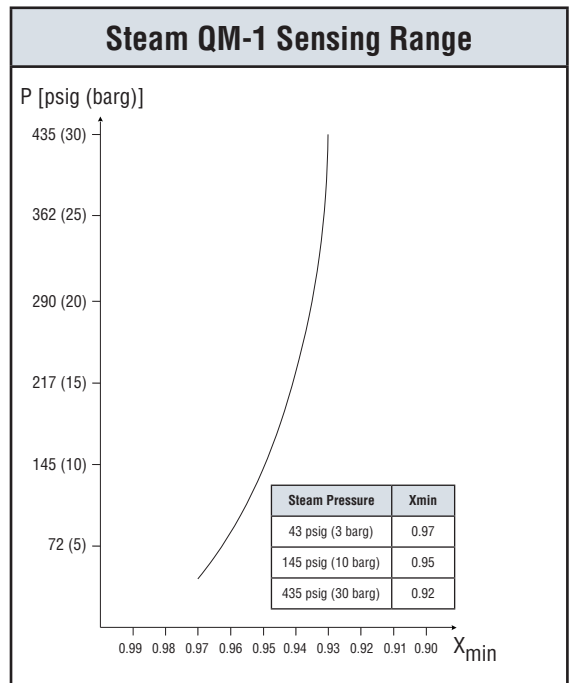

# Steam Quality Monitor – Steam QM-1

## Manual Versus Automatic

Until now steam dryness fraction measurement has been a time-intensive, unreliable and potentially unsafe process. Steam QM-1 is not only more reliable and safer than manual testing, the unit is also portable, so it can be easily transported to multiple points on your steam line.

When you compare Steam QM-1 to manual testing methods the choice is clear:

Manual Method	Automatic Method
<b>Description</b>	
<ul style="list-style-type: none"> <li>A sample of the steam is condensed during a limited time frame. Temperature and mass measurements allow calculation of the steam dryness.</li> </ul>	<ul style="list-style-type: none"> <li>Reducing steam pressure to atmosphere allows measurement of steam dryness.</li> </ul>
<b>Disadvantages</b>	
<ul style="list-style-type: none"> <li>Time Consuming: Typically manual steam quality measurement requires two people, and can take up to one hour per measurement point. This does not include additional time required to complete necessary reports.</li> <li>Trending: Unable to trend steam dryness over a period of time.</li> <li>Unsafe: There are inherent safety risks involved in sampling live steam and condensate in a water receiver.</li> <li>Unreliable: Measurement results depend on the skill of the technician conducting the test.</li> </ul>	<ul style="list-style-type: none"> <li>Quick and Easy: Steam QM-1 is simple to install.</li> <li>Trending: Continuous measurements provide trending data over time.</li> <li>Safe: Once QM-1 is installed it is much safer than manual measurement methods.</li> <li>Reliable: Steam QM-1 is both reliable and accurate.</li> </ul>
<b>Advantages</b>	

Steam QM-1 Dimensions & Weight		
	in	mm
A – Assembly Width	20	500
B – Assembly Height	15	375
C – Cabinet Width	10	250
D – Cabinet Height	6.5	160
E – Cabinet Depth	2.5	60
Assembly Weight	20 lb	9 kg
Cabinet Weight	2 lb	0.9 kg

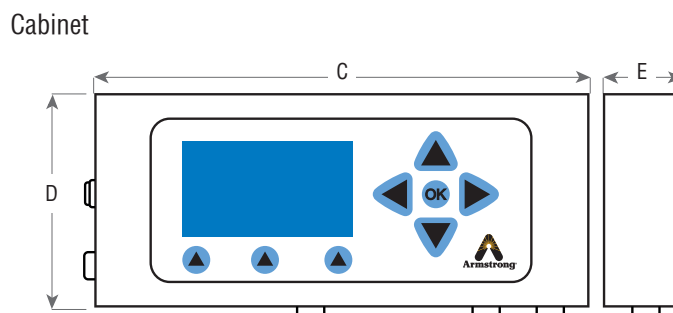
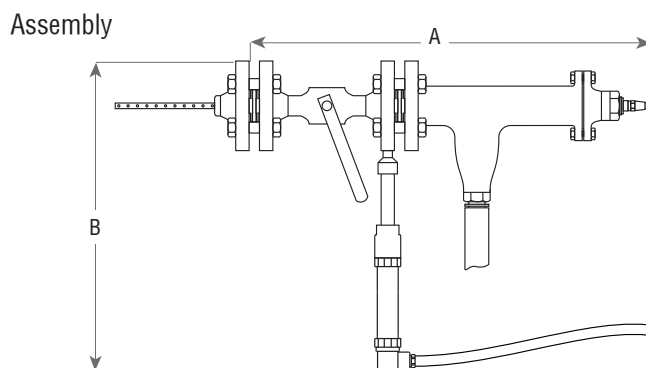

### Steam QM-1 Package Includes:

Insulation Cover • All Necessary Accessories

### Optional Feature:

Data Logger

**Armstrong** provides intelligent system solutions that improve utility performance, lower energy consumption, and reduce environmental emissions while providing an “enjoyable experience.”



**Armstrong** International  
North America • Latin America • India • Europe / Middle East / Africa • China • Pacific Rim  
[armstronginternational.com](http://armstronginternational.com)