



## Say energy. Think environment. And vice versa.

Any company that is energy conscious is also environmentally conscious. Less energy consumed means less waste, fewer emissions and a healthier environment.

In short, bringing energy and environment together lowers the cost industry must pay for both. By helping companies manage energy, Armstrong products and services are also helping to protect the environment.

Armstrong has been sharing know-how since we invented the energy-efficient inverted bucket steam trap in 1911. In the years since, customers' savings have proven again and again that knowledge *not* shared is energy wasted.

Armstrong's developments and improvements in drain trap design and function have led to countless savings in energy, time and money. This section has grown out of our decades of sharing and expanding what we've learned. It deals with the operating principles of drain traps and outlines their specific applications to a wide variety of products and industries.

This section also includes Recommendation Charts that summarize our findings on which type of drain trap will give optimum performance in a given situation and why.

## Terminology

Drain traps, as described in this section, have many other names in industry. A drain trap is an automatic loss prevention valve that opens to discharge liquids and closes to prevent air or gas loss. In industry, drain traps are also known as:

- Compressed air drains
- Condensate drainers
- Air traps
- Water traps
- Dump valves
- Float traps
- Liquid drainers
- Compressed air traps

This section should be utilized as a guide for the installation and operation of drain trapping equipment by experienced personnel. Selection or installation should always be accompanied by competent technical assistance or advice. We encourage you to contact Armstrong or its local representative for complete details.

# Instructions for Using the Recommendation Charts

Quick reference Recommendation Charts appear throughout the “HOW TO DRAIN” pages of this section, pages LD-17 to LD-28.

A feature code system (ranging from A to N) supplies you with “at-a-glance” information.

The chart covers the type of drain traps and the major advantages that Armstrong feels are superior for each particular application.

For example, assume you are looking for information concerning the proper trap to use on an aftercooler. You would:

1. Turn to the “How to Drain Aftercoolers” section, pages LD-21 and LD-22, and look in the lower left-hand corner of page LD-21. (Each application has a Recommendation Chart.) The Recommendation Chart LD-7 from page LD-21 is reprinted below as Chart LD-1 for your convenience.

2. Find “Aftercooler” in the first column under “Equipment Being Drained” and read to the right for Armstrong’s “1st Choice and Feature Code”. In this case, the first choice is an IB and the feature code letters F, G, J, K, M are listed.
3. Now refer to the chart below, titled “How Various Types of Drain Traps Meet Specific Operating Requirements” and read down the extreme left-hand column to each of the letters F, G, J, K, M. The letter “F,” for example, refers to the trap’s ability to handle oil/water mix.
4. Follow the line for “F” to the right until you reach the column that corresponds to our first choice, in this case the inverted bucket. Based on tests, actual operating conditions, and the fact that the discharge is at the top, the inverted bucket trap handles oil/water mixtures extremely well. Follow this same procedure for the remaining letters.

Chart LD-1. Recommendation Chart (See below for “Feature Code” references.)				
Equipment Being Drained	Air		Gas	
	1st Choice and Feature Code	Alternate Choice	1st Choice and Feature Code	Alternate Choice
Aftercooler	IB	FF	*FF	FP
Intercooler	F, G, J, K, M		B, E, J	

\*Since IBs vent gas to operate, an FF is suggested because gas venting may not be desirable.

Chart LD-2. How Various Types of Drain Traps Meet Specific Operating Requirements								
Feature Code	Characteristic	IB	FF	FP	FS	D	TV	MV
A	Method of Operation (Intermittent-Continuous)	I	C	C	I	I	I	C
B	Energy Conservation in Operation	Good	Excellent	Excellent	Excellent	Fair	Poor	Excellent
C	Energy Conservation Over Time	Good	Excellent	Excellent	Excellent	Poor	Fair	Poor (5)
D	Resistance to Wear Fair	Excellent	Excellent	Fair	Good	Poor	Good	Excellent
E	Corrosion Resistance	Excellent	Excellent	Excellent	Excellent	Excellent	Excellent	Excellent
F	Ability to Handle Oil/Water Mix	Excellent	Fair	Fair	Fair	Good	Excellent	Excellent
G	Ability to Prevent Sludge Buildup	Excellent	Poor	Poor	Fair	Good	Good	Excellent
H	Resistance to Damage from Freezing (1)	Good (2)	Poor	Poor	Poor	Good	Fair	Good
I	Performance to Very Light Loads	Good	Excellent	Excellent	Excellent	Poor	Poor	Poor
J	Responsiveness to Slugs of Liquid (3)	Good	Excellent	Excellent	Excellent	Poor	Poor	Poor
K	Ability to Handle Dirt	Excellent	Fair	Fair	Excellent	Poor	Excellent	Good
L	Comparative Physical Size	Large	Large	Large	Large	Small	Small	Small
M	Mechanical Failure (Open-Closed)	Open	Closed	Closed	Closed	Open	(4)	(4)
N	Noise Level of Discharge (Loud-Quiet)	Quiet	Quiet	Quiet	Quiet	Loud	Loud	(4)

- IB = Inverted Bucket
- FF = Float-Free Linkage
- FP = Float-Fixed Pivot Linkage
- FS = Float-Snap Acting Linkage
- D = Disc
- TV = Timed Solenoid Valve
- MV = Manual Valve

- (1) Cast iron not recommended.
- (2) Sealed stainless steel = good.
- (3) Float traps should be back vented = excellent.
- (4) Can be either.
- (5) Usually end up “cracked open.”

Liquid Drainers



# Compressed Air/Gases—Basic Concepts

Moisture is always present in compressed air, and oil can be present at some points in a compressed air system. For the efficient operation and long life of gaskets, hoses and air tools, this excess moisture and the oil must be removed from the system.

The removal of moisture and oil from a system involves more than just traps. To maintain high efficiency and avoid costly problems, a compressed air system also requires:

1. Aftercoolers to bring the compressed air down to ambient or room temperature.
2. Separators to knock down suspended droplets of water or fog. Separators are installed downstream from aftercoolers or in air lines near point of use, or both.
3. Drain traps to discharge the liquid from the system with a minimum loss of air.

**Table LD-1. Weight of Water Per Cubic Foot of Air at Various Temperatures**

Temp. °F	Percentage of Saturation									
	10	20	30	40	50	60	70	80	90	100
	Grains	Grains	Grains	Grains	Grains	Grains	Grains	Grains	Grains	Grains
-10	.028	.057	.086	.114	.142	.171	.200	.228	.256	.285
<b>0</b>	<b>.048</b>	<b>.096</b>	<b>.144</b>	<b>.192</b>	<b>.240</b>	<b>.289</b>	<b>.337</b>	<b>.385</b>	<b>.433</b>	<b>.481</b>
10	.078	.155	.233	.310	.388	.466	.543	.621	.698	.776
20	.124	.247	.370	.494	.618	.741	.864	.988	1.112	1.235
<b>30</b>	<b>.194</b>	<b>.387</b>	<b>.580</b>	<b>.774</b>	<b>.968</b>	<b>1.161</b>	<b>1.354</b>	<b>1.548</b>	<b>1.742</b>	<b>1.935</b>
32	.211	.422	.634	.845	1.056	1.268	1.479	1.690	1.902	2.113
35	.237	.473	.710	.946	1.183	1.420	1.656	1.893	2.129	2.366
<b>40</b>	<b>.285</b>	<b>.570</b>	<b>.855</b>	<b>1.140</b>	<b>1.424</b>	<b>1.709</b>	<b>1.994</b>	<b>2.279</b>	<b>2.564</b>	<b>2.849</b>
45	.341	.683	1.024	1.366	1.707	2.048	2.390	2.731	3.073	3.414
50	.408	.815	1.223	1.630	2.038	2.446	2.853	3.261	3.668	4.076
<b>55</b>	<b>.485</b>	<b>.970</b>	<b>1.455</b>	<b>1.940</b>	<b>2.424</b>	<b>2.909</b>	<b>3.394</b>	<b>3.879</b>	<b>4.364</b>	<b>4.849</b>
60	.574	1.149	1.724	2.298	2.872	3.447	4.022	4.596	5.170	5.745
62	.614	1.228	1.843	2.457	3.071	3.685	4.299	4.914	5.528	6.142
<b>64</b>	<b>.656</b>	<b>1.313</b>	<b>1.969</b>	<b>2.625</b>	<b>3.282</b>	<b>3.938</b>	<b>4.594</b>	<b>5.250</b>	<b>5.907</b>	<b>6.563</b>
66	.701	1.402	2.103	2.804	3.504	4.205	4.906	5.607	6.308	7.009
68	.748	1.496	2.244	2.992	3.740	4.488	5.236	5.984	6.732	7.480
<b>70</b>	<b>.798</b>	<b>1.596</b>	<b>2.394</b>	<b>3.192</b>	<b>3.990</b>	<b>4.788</b>	<b>5.586</b>	<b>6.384</b>	<b>7.182</b>	<b>7.980</b>
72	.851	1.702	2.552	3.403	4.254	5.105	5.956	6.806	7.657	8.508
74	.907	1.813	2.720	3.626	4.533	5.440	6.346	7.253	8.159	9.066
<b>76</b>	<b>.966</b>	<b>1.931</b>	<b>2.896</b>	<b>3.862</b>	<b>4.828</b>	<b>5.793</b>	<b>6.758</b>	<b>7.724</b>	<b>8.690</b>	<b>9.655</b>
78	1.028	2.055	3.083	4.111	5.138	6.166	7.194	8.222	9.249	10.277
80	1.093	2.187	3.280	4.374	5.467	6.560	7.654	8.747	9.841	10.934
<b>82</b>	<b>1.163</b>	<b>2.325</b>	<b>3.488</b>	<b>4.650</b>	<b>5.813</b>	<b>6.976</b>	<b>8.138</b>	<b>9.301</b>	<b>10.463</b>	<b>11.625</b>
84	1.236	2.471	3.707	4.942	6.178	7.414	8.649	9.885	11.120	12.326
86	1.313	2.625	3.938	5.251	6.564	7.877	9.189	10.502	11.814	13.137
<b>88</b>	<b>1.394</b>	<b>2.787</b>	<b>4.181</b>	<b>5.575</b>	<b>6.968</b>	<b>8.362</b>	<b>9.756</b>	<b>11.150</b>	<b>12.543</b>	<b>13.997</b>
90	1.479	2.958	4.437	5.916	7.395	8.874	10.353	11.832	13.311	14.780
92	1.569	3.138	4.707	6.276	7.844	9.413	10.982	12.551	14.120	15.639
<b>94</b>	<b>1.663</b>	<b>3.327</b>	<b>4.990</b>	<b>6.654</b>	<b>8.317</b>	<b>9.980</b>	<b>11.644</b>	<b>13.307</b>	<b>14.971</b>	<b>16.624</b>
96	1.763	3.525	5.288	7.050	8.813	10.576	12.338	14.101	15.863	17.676
98	1.867	3.734	5.601	7.468	9.336	11.203	13.070	14.937	16.804	18.661
<b>100</b>	<b>1.977</b>	<b>3.953</b>	<b>5.930</b>	<b>7.906</b>	<b>9.883</b>	<b>11.860</b>	<b>13.836</b>	<b>15.813</b>	<b>17.789</b>	<b>19.766</b>

Based on atmospheric pressure of 14.7 psia.

# Compressed Air/Gases—Basic Concepts

Water carried with air into tools or machines where air is being used will wash away lubricating oil. This causes excess wear to motors and bearings and results in high maintenance expense. Without adequate lubrication, the tools and machines run sluggishly and their efficiency is lowered. This effect is particularly pronounced in the case of pneumatic hammers, drills, hoists and sand rammers, where the wearing surfaces are limited in size and the excessive wear creates air leakage.

Where air is used for paint spraying, enameling, food agitation and similar processes, the presence of water and/or oil cannot be tolerated, nor can particles of grit or scale.

In instrument air systems, water will tend to cling to small orifices and collect dirt, causing erratic operation or failure of sensitive devices.

## Pipeline Troubles

When water accumulates at low points in the pipeline, the air-carrying capacity of the line is reduced. Eventually, airflow over the pool of water will begin to carry the water along at high velocity. This produces “water hammer” along the line, and may even carry over a slug of water into a tool. In cold weather, accumulations of water may freeze and burst pipelines.

## Air’s Capacity to Hold Moisture

At atmospheric pressure (14.7 psia), 8 cu ft of air with an RH of 50% and a temperature of 70°F will contain 32 grains of moisture vapor.

When the pressure is doubled (without increasing the temperature) the volume is cut in half (4 cu ft), but there are still 32 grains of moisture. This means the relative humidity is now 100%—all the moisture in vapor form that it can handle.

Increasing the pressure to 100 psig (114.7 psia), the volume of air is further reduced to approximately 1 cu ft. This 1 cu ft of compressed air still at 70°F can hold a maximum eight grains of moisture.

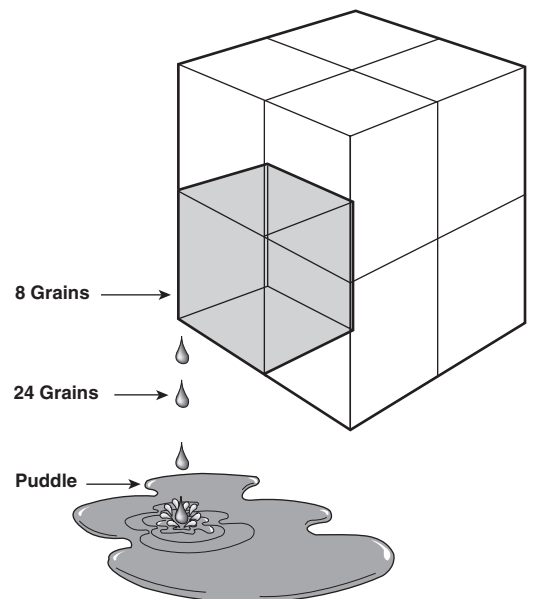
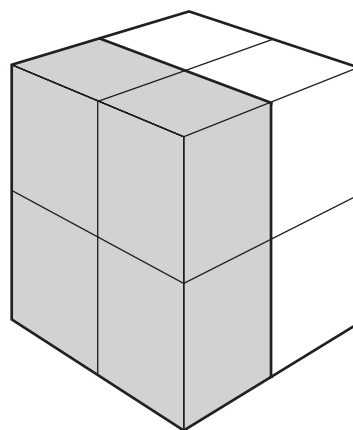
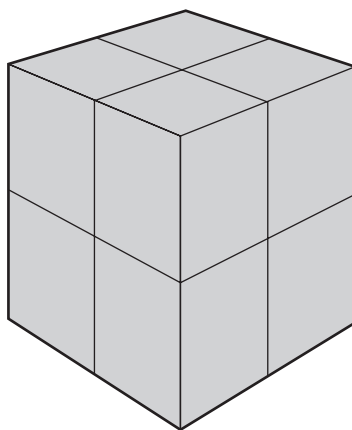

**Figure LD-1.**

Pressure: 0 psig (14.7 psia)  
 Temp: 70°F  
 Air = 8 CF  
 Moisture = 32 Grains  
 Max Possible = 64 Grains

**Figure LD-2.**

Pressure: 15 psig (29.7 psia)  
 Temp: 70°F  
 Air = 4 CF  
 Moisture = 32 Grains  
 Max Possible = 32 Grains

**Figure LD-3.**

Pressure: 100 psig (114.7 psia)  
 Temp: 70°F  
 Air = 1 CF  
 Moisture = 32 Grains  
 Max Possible = 8 Grains  
 24 Grains  
 of Liquid

Designs, materials, weights and performance ratings are approximate and subject to change without notice. Visit [armstronginternational.com](http://armstronginternational.com) for up-to-date information.

## Drainage Problems and How to Avoid Them

**Oil.** A critical drainage problem exists at points where oil may be present in the compressed air (principally at intercoolers, aftercoolers and receivers).

Two facts create this problem:

1. Oil is lighter than water and will float on top of water.
2. Compressor oil when cooled tends to become thick and viscous.

The beaker simulates any drain trap that has its discharge valve at the bottom, Fig. LD-4. Like the beaker, the trap will fill with heavy oil that may be thick and viscous.

Compare with Fig. LD-5, which shows an identical beaker except that the discharge valve is at the same level as the oil. Oil will escape until the oil level is so thin that for every 19 drops of water and one of oil that enter the beaker, exactly 19 drops of water and one drop of oil will leave. The beaker always will be filled with water.

The conclusion is obvious. When there is an oil-water mixture to be drained from an air separator or receiver, use a trap with the discharge valve at the top.

**Dirt and Grit.** While scale and sediment is seldom a problem between the compressor and receiver, it is encountered in the air distribution system, particularly when the piping is old. In this situation, scale will be carried to a drain trap along with the water. If the drain trap is not designed to handle dirt and grit, the trap may fail to drain water and oil, or the trap valve may not close.

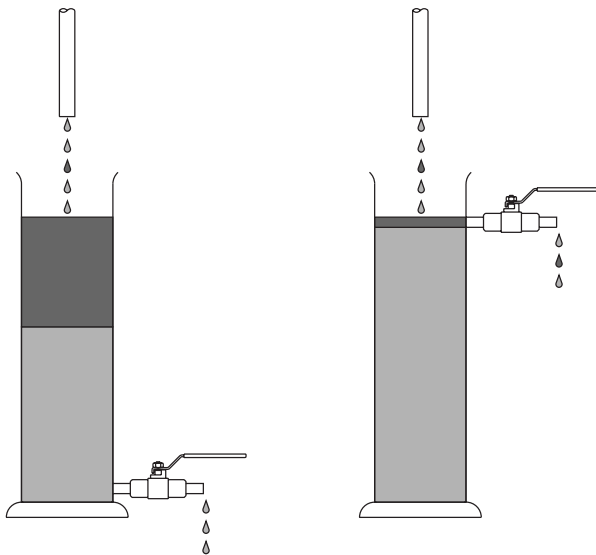

**Figure LD-4.** If a beaker collecting oil and water is drained from the bottom at the same rate that oil and water enter, it will eventually fill entirely with oil because oil floats on water.

**Figure LD-5.** If a beaker collecting oil and water is drained from the top at the same rate that oil and water enter, it soon will be entirely filled with water because the oil floats on the water.

**Air Loss.** Often in compressed air systems, the solution to one problem may also cause another problem. For example, a common method of draining unwanted moisture is to crack open a valve; however, this also creates a leak. The immediate problem is solved, but the “solution” has an obvious, and usually underestimated, cost of continual air loss.

How much air is lost depends on orifice size and line pressure (see Table LD-2). The overall result is a decrease in line pressure, the loss of up to a third of the system’s compressed air, and the cost of compressing it.

Leak control involves:

- Looking for leaks during shut-down with an ultrasonic leak detector
- Determining total leakage by observing how fast pressure drops with the compressor off, both before and after a leak survey
- Fixing leaks at joints, valves and similar points
- Replacing cracked-open valves with drain traps
- Checking the system regularly

## Figure LD-6. Drain Trap Locations in a Compressed Air System

The use of drain traps is an effective way to remove water that collects in many places in a compressed air system. Each trap location must be considered individually.

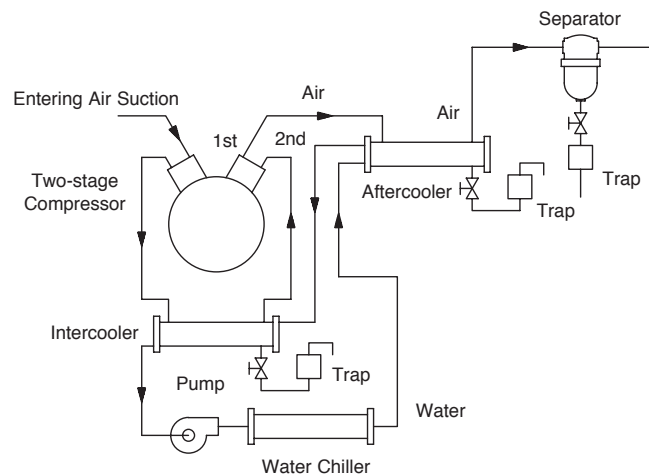

# Compressed Air/Gases—Basic Concepts

## Drainage Methods

**Manual.** Liquid may be discharged continuously through cracked-open valves, or periodically by opening manually operated drain valves.

Open drains are a continuous waste of air or gas—and the energy to produce it. A valve manually opened will be left open until air blows freely. Frequently, however, the operator will delay or forget to close the valve, and precious air or gas is lost.

**Automatic.** Automatic drainage equipment that is adequate for the system is seldom included in the original system. However, subsequent installation of automatic drain traps will significantly reduce energy and maintenance costs.

**Drain Traps.** Water collected in separators and drip legs must be removed continuously without wasting costly air or gas. In instances where drain traps are not part of the system design, manual drain valves are usually opened periodically or left cracked open to drain constantly. In either case, the valves are opened far enough that some air and gas are lost along with the liquid. To eliminate this problem, a drain trap should be installed at appropriate points to remove liquid continuously and automatically without wasting air or gas.

The job of the drain trap is to get liquid and oil out of the compressed air/gas system. In addition, for overall efficiency and economy, the trap must provide:

- Operation that is relatively trouble-free with minimal need for adjustment or maintenance
- Reliable operation even though dirt, grit and oil are present in the line
- Long operating life
- Minimal air loss
- Ease of repair

**Table LD-2. Cost of Various Size Air Leaks at 90 psig**

Orifice Diameter (in)	Leakage Rate (scfm)	Total Cost Per Month	Cost Total Per Year
3/8	138.00	\$1,207.50	\$14,490
1/4	61.00	533.75	6,405
1/8	<b>15.40</b>	<b>134.75</b>	<b>1,617</b>
7/64	11.80	103.25	1,239
5/64	6.00	52.50	630
1/16	<b>3.84</b>	<b>33.60</b>	<b>403</b>

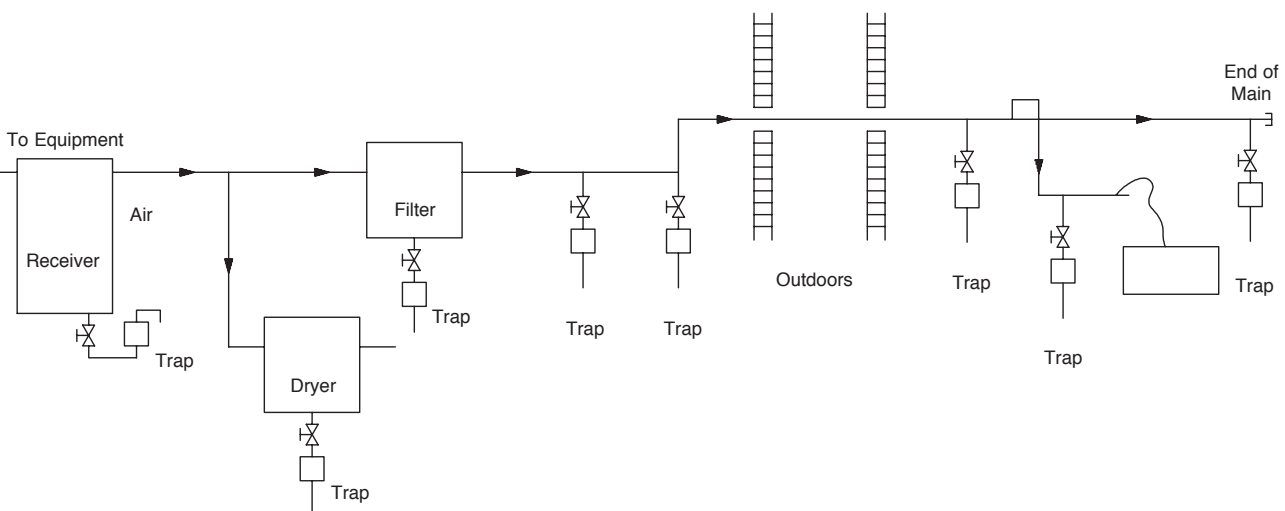

## For Heavy Oil/Water Service

BVSW inverted bucket drain traps are designed for systems with heavy oil or water services.

An inverted bucket is used because the discharge valve is at the top, so oil is discharged first and the trap body is almost completely filled with water at all times.

BVSW stands for Bucket Vent Scrubbing Wire. This 1/16" dia. wire swings freely from the trap cap and extends through the bucket vent. Its function is to prevent reduction of vent size by buildup of solids or heavy oil in the vent itself. The up-and-down motion of the bucket relative to the vent scrubbing wire keeps the vent clean and full size.

## Operation of Inverted Bucket Drain Traps

1. Since there is seldom sufficient accumulation of water to float the bucket and close the valve, the trap must be primed on initial start-up or after draining for cleaning. Step 1 shows "after operating" primed condition with oil in the top of bucket and a very thin layer of water in the trap body.
2. When valve in line to trap is opened, air enters bucket, displacing liquid. When bucket is two-thirds full of air, it becomes buoyant and floats. This closes the discharge valve. As bucket rises, the vent scrubbing wire removes oil and any dirt from bucket vent.

Both liquid and air in trap are at full line pressure, so no more liquid or air can enter trap until some liquid or air escapes through the discharge valve. Static head forces air through bucket vent. The air rises to top of trap and displaces water that enters bucket at bottom to replace air that passes through vent. Just as soon as bucket is less than two-thirds full of air, it loses buoyancy and starts to pull on valve lever as shown in Step 3.

Figure LD-7. Operation of the BVSW Inverted Bucket Drain Trap

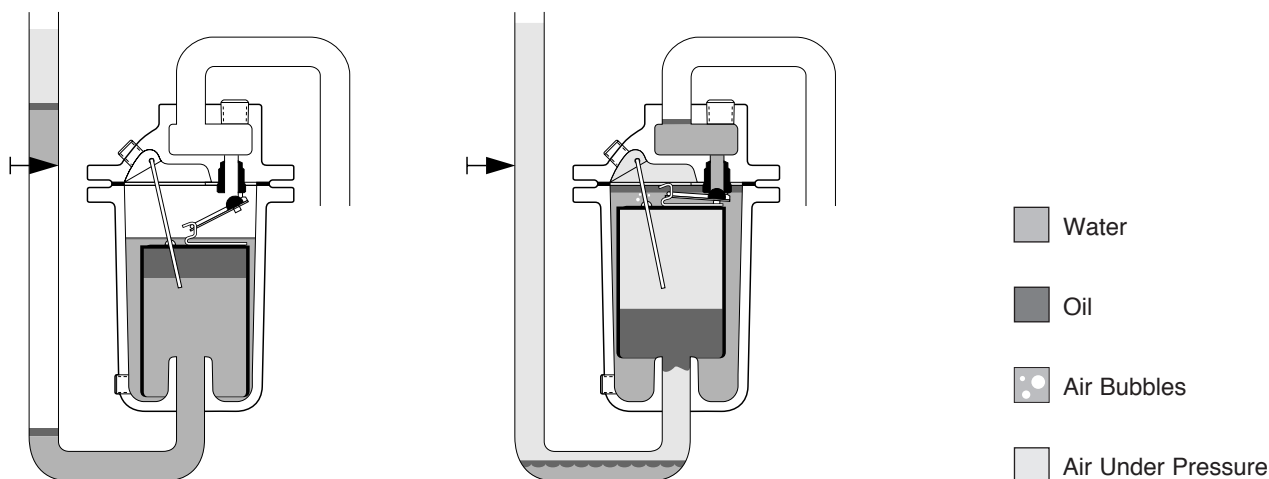

1. Trap primed, air off, bucket down, trap valve open.

2. Trap in service, bucket floating. Air passes through bucket vent and collects at top of trap.

# Inverted Bucket Drain Traps

3. Note that liquid level at top of trap has dropped and the liquid level in the bucket has risen. The volume of water displaced by air exactly equals the volume of water that entered the bucket. During this valve-closed part of the operating cycle—Steps 2 and 3—water and oil are collecting in the horizontal line ahead of the trap. When the bucket is about two-thirds full of liquid, it exerts enough pull on lever to crack open the discharge valve.
4. Two things happen simultaneously. a) The accumulated air at top of trap is discharged immediately, followed by oil and any water that enters the trap while the valve is cracked. b) Pressure in trap body is lowered slightly, allowing accumulated liquid in horizontal line to enter the trap. Air displaces liquid from the bucket until it floats and closes the discharge valve, restoring the condition shown in Step 2.
5. When full buoyancy is restored, the trap bucket is two-thirds full of air. Oil that has entered while trap was open flows under bottom of bucket and rises to top of water in trap body. The trap normally discharges small quantities of air several times per minute.

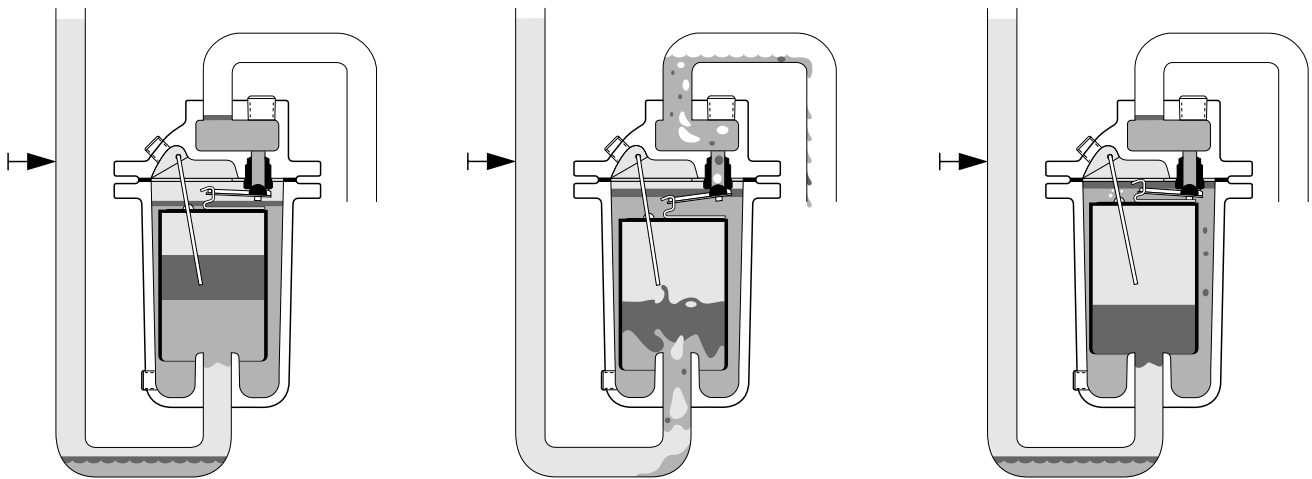

3. Water enters bucket to replace air passing through bucket vent. This increases weight of bucket until...
4. ...pull on lever cracks valve. Air at top of trap escapes, followed by oil and water. Liquid in pipe ahead of trap enters bucket followed by air.
5. Air displaces liquid and excess oil from bucket, restoring condition shown in Step 2.

Designs, materials, weights and performance ratings are approximate and subject to change without notice. Visit [armstronginternational.com](http://armstronginternational.com) for up-to-date information.



## Closed Float

Hollow, thin-wall metal floats are attached through linkages to valves at the trap bottom, and a seat with an appropriately sized orifice is inserted at the trap outlet. Floats are selected to provide adequate buoyancy to open the valve against the pressure difference. Discharge usually is to atmosphere, so the pressure drop is equal to the system air pressure. The float and linkage are made of stainless steel, and the valve and seat are hardened stainless steel for wear resistance and long life. The body is cast iron, stainless steel, or cast or forged steel depending on gas pressure. Bodies may be made of stainless steel to resist corrosive gas mixtures.

Entering liquid drops to the bottom of the body. As liquid level rises, the ball is floated upward, thereby causing the valve to open sufficiently that outlet flow balances inlet flow. Subsequent change of incoming flow raises or

lowers water level further opening or throttling the valve. Thus discharge is proportionally modulated to drain liquid completely and continuously. However, gas flow may be constant or it may abruptly change depending on system demand characteristics. Liquid formation may be sporadic, or the nature of flow generation may cause surges. At times, flow will be very low, requiring operation to throttle the flow or even tight shut-off. Tightness of closure, gas leakage and trap cost will depend on the design of linkage and valve.

## Free Floating Lever

The discharge from the No. 1-LD is continuous. The opening of the valve is just wide enough to remove the liquid as fast as it comes to the trap. Thus, at times, the valve is barely cracked from its seat.

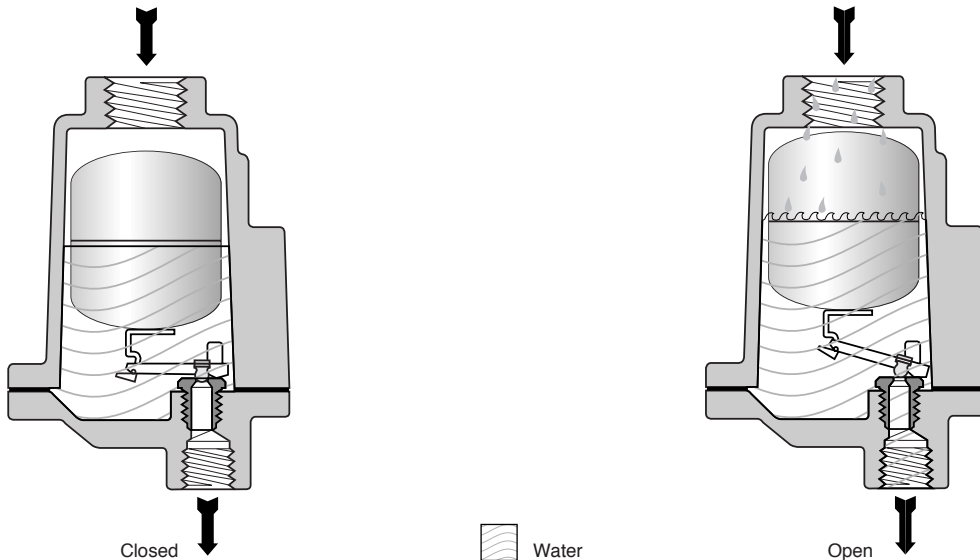

**Figure LD-8. Operation of the No. 1-LD Free Floating Lever Drain Trap**  
As water begins to fill the body of the trap, the float rises, opening the discharge valve. Motion of the free floating valve lever is guided to provide precise closure.

## Free Floating Linkage Valve

A hemispherical ball-shaped valve is attached to linkage which is suspended freely on two guide pins. There is no fixed pivot or rigid guides; therefore, the attachment is loose. There are no critical alignments, and the lever and valve may move in all directions. Consequently, the lever may

move the valve to the seat in any alignment. As the valve approaches the seat, the pressure pushes the round valve into the square edge orifice of the seat, effecting a line seal to attain bubble-tight closure.

**Figure LD-9. Free Floating Linkage**

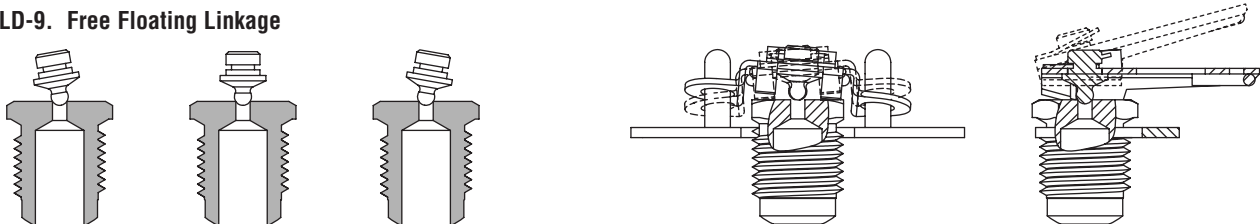

Designs, materials, weights and performance ratings are approximate and subject to change without notice. Visit [armstronginternational.com](http://armstronginternational.com) for up-to-date information.

# Float Type Drain Traps

## Fixed Pivot Conical Valve

A conically shaped valve is attached to a fixed pivot leverage system. The fixed pivot does not allow the valve to move

freely to conform to the seat for tight closure. Thus, it may not seal tightly, and some loss of air or gas may be expected.

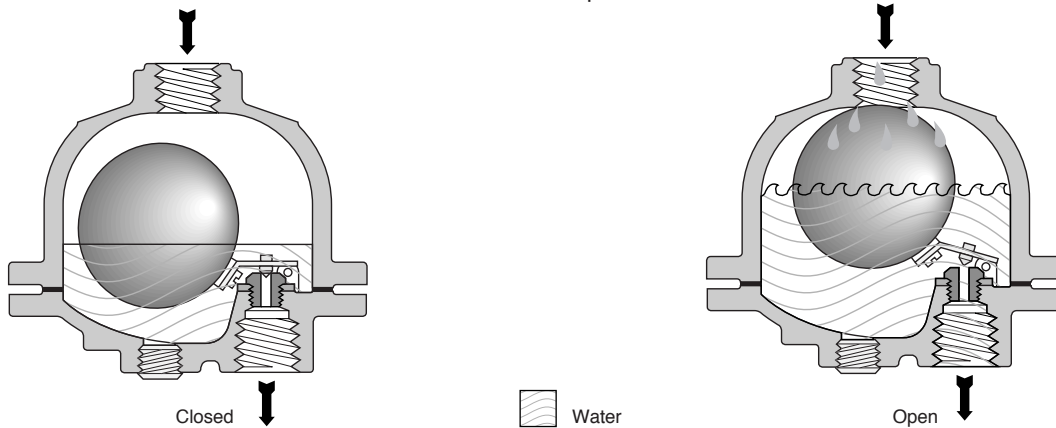

**Figure LD-10. Operation of No. 21 Fixed Pivot Drain Trap**

As the water level rises, the ball float cracks the valve to drain liquid at the same rate that it reaches the trap. Changes in the rate of flow to the trap adjust the float level and the degree of opening of the valve.

## Snap Action Valve

Because of the sporadic liquid flow, much of the time the valve in a standard float-type drainer is only slightly opened. If there is fine dirt or grit in the liquid, particles may accumulate and clog the partially open valve, or they may lodge between the valve and seat, preventing closure. To overcome this, a special toggle-spring operated valve is used.

A flat spring attached to the leverage system holds the valve closed until liquid level is high enough for the buoyancy to exceed the spring force. Then the valve is snapped open, and the accumulated dirt and grit can be flushed through the wide open valve. When the body is nearly empty, buoyancy is reduced enough to permit the spring to snap the valve closed.

**Figure LD-11. Operation of No. 71-A Snap Action Drain Trap**

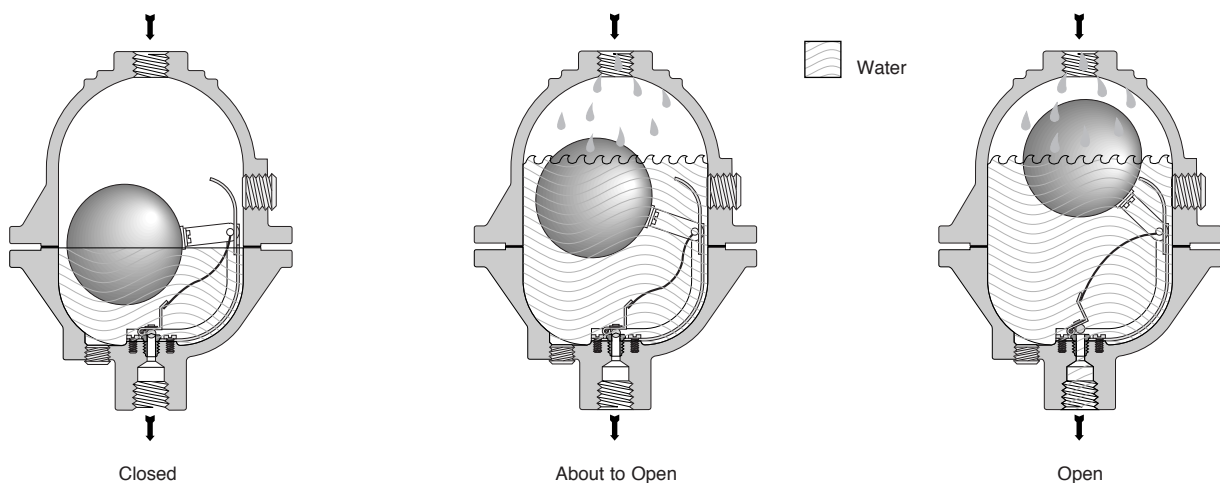

**Filling Cycle.** Trap valve has just closed. Spring bowed to right. Float rides high in water because no force is exerted on spring. As water enters, float rises, storing energy in spring. This increases submergence of float.

Float now is more than half submerged and spring has assumed a "handlebar mustache" shape. Energy stored in spring is due to increased displacement of water. A very slight rise in water level causes spring to snap to the left...

...Instantly the valve opens wide. This releases energy from spring and float again rides high in water. As water level drops, weight of float bends spring to right, causing snap closing of valve before all the water has been discharged.

Designs, materials, weights and performance ratings are approximate and subject to change without notice. Visit [armstronginternational.com](http://armstronginternational.com) for up-to-date information.



# Armstrong® Drain Trap Selection

To obtain the full benefits from the traps described in the preceding section, it is necessary that the correct size and pressure of drain trap be selected for each job, and that it be properly installed and maintained.

**Rely on Experience.** Most drain traps are selected on the basis of experience. This may be:

- Your personal experience
- The experience of your Armstrong Representative or distributor
- The experience of thousands of others in draining identical equipment

**Do-It-Yourself Sizing** is required at times. Fortunately, drain trap sizing is simple when you know or can figure:

1. Liquid loads in lbs/hr.
2. Pressure differential.
3. Maximum allowable pressure.

**1. Liquid Load.** Each “How To” section of this handbook contains formulas and useful information on proper sizing procedures and safety factors.

**2. Pressure Differential. Maximum differential** is the difference between main pressure, or the downstream pressure of a PRV, and return line pressure. See Fig. LD-12. The drain trap must be able to open against this pressure differential.

**Operating differential.** When the plant is operating at capacity, the pressure at the trap inlet may be lower than main pressure. And the pressure in the return header may go above atmospheric.

If the operating differential is at least 80% of the maximum differential, it is safe to use maximum differential in selecting traps.

**IMPORTANT:** Be sure to read the discussion on page LD-16, which deals with less common, but important, reductions in pressure differential.

**3. Maximum Allowable Pressure.** The trap must be able to withstand the maximum allowable pressure of the system, or design pressure. It may not have to operate at this pressure, but it must be able to contain it. As an example, the maximum inlet pressure is 150 psig and the return line pressure is 15 psig. This results in a differential pressure of 135 psi; however, the trap must be able to withstand 150 psig maximum allowable pressure. See Fig. LD-12.

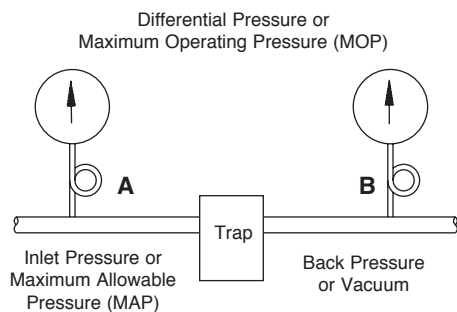

**Figure LD-12.** “A” minus “B” is Pressure Differential: If “B” is back pressure, subtract it from “A.” If “B” is vacuum, add it to “A.”

# Drain Trap Selection

## Factors Affecting Pressure Differential

### Pressure Differential in Detail

Inlet pressure can be:

1. Air main pressure.
2. Reduced pressure controlled by a pressure reducing valve station.

Discharge can be:

1. Atmospheric.
2. Below atmospheric—under vacuum. Add vacuum to inlet pressure to get pressure differential.  
2" Hg vacuum = approximately 1 psi of pressure below atmospheric.
3. Above atmospheric due to:
  - a. Pipe friction
  - b. Elevating liquid

Every 2' lift reduces pressure differential by approximately 1 psi, when the discharge is only liquid.

## Special Considerations

Drain traps are available for services other than those found on standard compressed air systems.

### High Pressure

Spring-loaded mechanisms allow float type drain traps to operate on pressures above 3,000 psi.

### Fluids Other Than Water

Different fluids, such as oils and liquid, can be compensated for with specially weighted floats or lower operating pressure ratings. Fluids with specific gravities down to 0.4 will work with float type drain traps.

### Materials of Construction

Service requirements for stainless steel or other corrosion-resistant materials can be met by float and inverted bucket type drain traps.

### NACE Sour Gas Service

Special materials and construction are required for hydrogen sulfide service.

### High Capacity for Large Flow Rates

Ultra-capacity type drain traps allow float type drain traps to be used on service requiring capacities up to 700,000 lbs/hr.

### Dual Gravity

Float type drain traps can be modified to drain a heavier fluid from a lighter fluid.

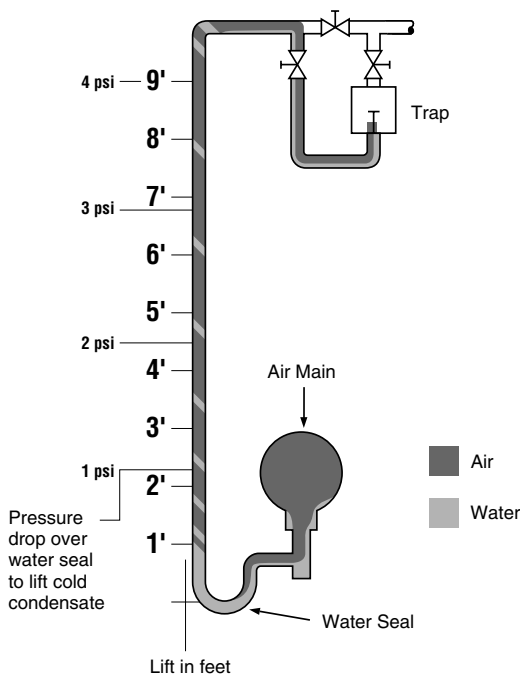

**Figure LD-13.** Liquid from gravity drain point is lifted to trap by a syphon. Every 2' of lift reduces pressure differential by approximately 1 psi. Note seal at low point and the trap's internal check valve to prevent back flow.

Air distribution systems make up the vital link between compressors and the vast amount of air-utilizing equipment. They represent the method by which air is actually transported to all parts of the plant to perform specific functions.

The three primary components of air distribution systems are air mains, air branch lines, and air distribution manifolds. They each fill certain requirements of the system, and together with separators and traps, contribute to efficient air utilization. Common to all air distribution systems is the need for drip legs at various intervals. These drip legs are provided to:

1. Let liquid escape by gravity from the fast-moving air.
2. Store the liquid until the pressure differential can discharge it through the drain trap.
3. Serve as dirt pockets for the inevitable dirt and grit that will accumulate in the distribution system.

Air mains are one of the most common applications for drain traps. These lines need to be kept free of liquid to keep the supplied equipment operating properly. Inadequately trapped air mains often result in water hammer and slugs of liquid, which can damage control valves and other equipment. There is also a freeze potential wherever water is allowed to accumulate. In areas where air is moving slowly, the accumulation of water can effectively reduce the pipe size, thereby increasing the pressure drop and wasting energy.

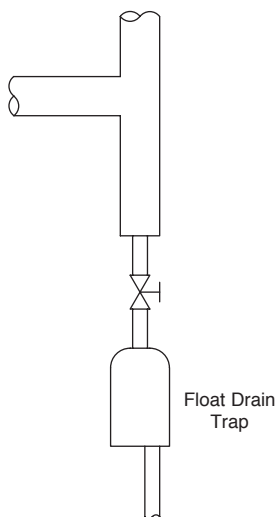

**Figure LD-14.** Drain trap installed straight under a low point.

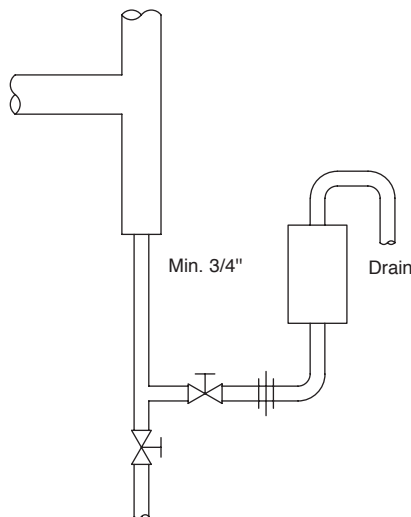

**Figure LD-15.** Series 200 or 300 inverted bucket drain traps installed on compressed air line contaminated by oil.

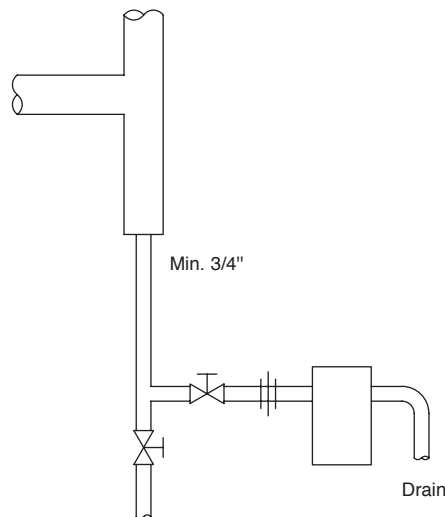

**Figure LD-16.** Series 800 or 900 inverted bucket drain traps installed on compressed air line contaminated by oil.

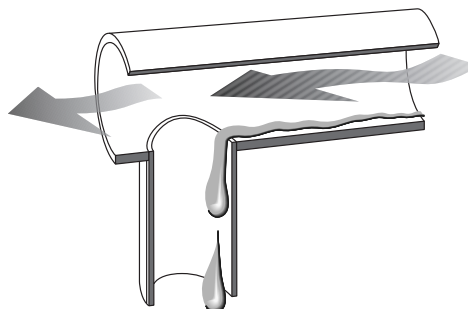

**Figure LD-17.** Drip leg length should be at least 1-1/2 times the diameter of the main and never less than 10". Drip leg diameter should be the same size as the main, up to 4" pipe size and at least 1/2 of the diameter of the main above that, but never less than 4".

**Chart LD-3. Recommendation Chart**

(See chart on page LD-6 for "Feature Code" references.)

Equipment Being Drained	1st Choice and Feature Code	Alternate Choice and Feature Code
Air Mains	FF B, C, D, J, M	FP*

\*IB is a good alternative where heavy oil carryover is likely.

Designs, materials, weights and performance ratings are approximate and subject to change without notice. Visit [armstronginternational.com](http://armstronginternational.com) for up-to-date information.

# How to Drain Air Distribution Systems

## Selection of Drain Traps and Safety Factor for Air Mains

Traps should be selected to discharge a volume of liquid normally produced when the system is up and running. Liquid loads can be estimated if actual CFM or air volume flow is not known. If cold temperatures are possible, the dew point at supply pressure must be known. Once this maximum is determined, the safety factor used to size the trap will be only 10% of the total potential liquid load. Ten percent of the total is used because most of the liquid has been removed in the aftercooler and receiver. The drain trap must handle only the small remaining amount of 10% of the total possible load.

If actual airflow rate is not known, it can be estimated using Chart LD-4, titled "Pressure Drop in Compressed Air Pipe." Using an assumed pressure drop of 1/4 (.25) psi per 100 ft, and 100 psi gauge pressure of air through a 4" line, it can be seen that approximately 1,000 cu ft of free air per minute are flowing through the line. Taking this figure to the chart titled "Water Condensed From Compressed Air," Chart LD-20 on page LD-20, it can be seen that if 80°F, 90% RH air is delivered at 100 psi, then 1.2 lbs of water will be condensed per minute at 1,000 CFM. This number will be multiplied by 60 to convert from minutes to hours, which equals 72 lbs/hr. For this air main then, take 10% of this figure, or 7.2 lbs/hr, to be the flow rate to the drainer.

### Rule of Thumb for Calculating Compressor Liquid Loads

$$\frac{\text{CFM} \times 20 \text{ gr/cu ft} \times 60 \text{ min/hr}}{7,000 \text{ gr/\#}} = \text{\#/hr}$$

1. Assuming worst condition:  
100°F @ 100% RH  
For other conditions, see page LD-7
2. Using air main safety factor of: Load x 10%

## Installation of Drain Traps on Air Mains

**Drip Legs.** All air mains should utilize drip legs and traps at all low spots or natural drainage points, such as ahead of risers, end of mains, ahead of expansion joints or bends, and ahead of valves and regulators (see installation Fig. LD-17).

Where there are no natural drainage points, drip legs and drain traps should still be provided. These should normally be installed at intervals of about 500 ft.

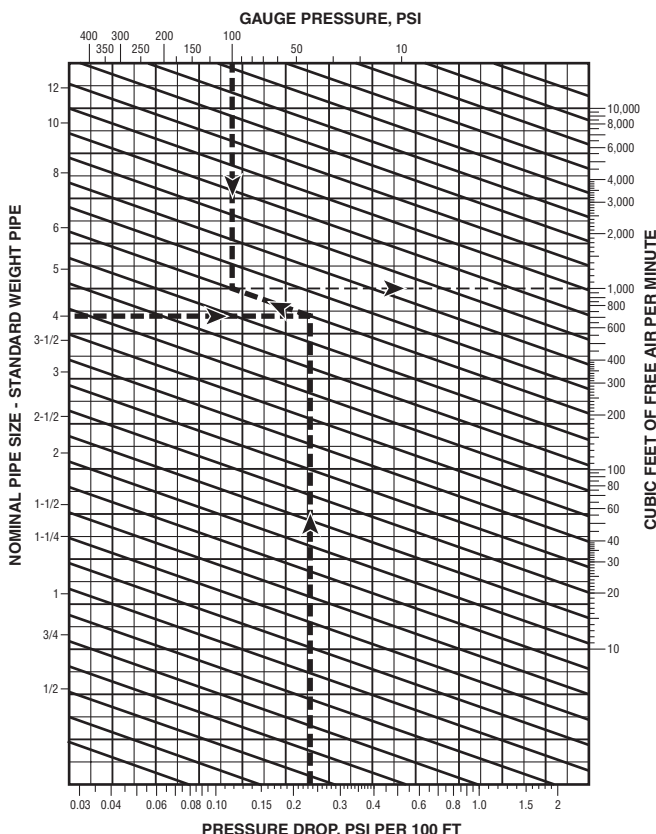

**Chart LD-4. Pressure Drop in Compressed Air Pipe**

Chart gives pressure drop in compressed air piping in pounds per square inch per 100 ft of pipe. Initial pressure, flow and size of pipe must be known or assumed.

## Branch Lines

Branch lines are takeoffs of the air main supplying specific areas of air-utilizing equipment. Branch lines must always be taken from the top of the air main. The entire system must be designed and hooked up to prevent accumulation of liquid at any point. If a specific process area requires it, an air dryer will be installed on the branch line.

### Trap Selection and Safety Factor for Branches

The formula for computing liquid load in branch lines is the same as that used for air mains. Branch lines also have a recommended safety factor of 10% of total air load. Drip legs must be installed ahead of risers and at the end of branch lines, especially when branch line runouts exceed 50 ft. There are usually several branches off the air main, and in many cases they experience a high liquid load when they run against cold outside walls. This cooling causes more moisture to condense in the branch line than would be seen in the air main.

## Distribution Manifolds

A distribution manifold is a terminal for a branch line from which several air users are taken off. They are particularly common in manufacturing facilities for pneumatic tool hookups or takeoffs to cylinder actuators. Like branch lines, it is common for distribution manifolds to be installed against cool walls where low temperatures cause condensation and the accumulation of liquid.

Distribution manifolds are often equipped with filters and regulators. Regulators may also be found at the termination before the air-using device.

Since the air distribution manifold is usually one pipe size larger than the branch line, it is common for air velocity to drop when coming from the branch line. With this decrease in velocity, often combined with lower ambient temperatures, it is common for a liquid to accumulate in the distribution manifold. For this reason, the use of filter-drainer combinations or separate drain traps is recommended. Trapping the liquid in the distribution manifold is important to protect the regulators on air-using equipment and orifices in air-using instruments.

This is a location where manual valves are commonly misused due to their accessibility. To drain the liquid and keep it from fouling an instrument or pneumatic tool, manual valves will often be cracked to atmosphere. When they are left this way, the result is a large air loss due to the unrestricted free blow of air to atmosphere.

### Trap Selection and Safety Factor for Distribution Manifolds

Normally the smallest drain trap is practical for distribution manifolds up to manifold diameters of 2". Above 2", the distribution manifold should be considered a branch, and then the sizing procedure from the Air Main section would apply.

**Chart LD-5. Recommendation Chart**

(See chart on page LD-6 for "Feature Code" references.)

Equipment Being Drained	1st Choice and Feature Code	Alternate Choice
Branch Lines	FF B, C, D, J, M	FP*
Distribution Manifolds	FF B, C, D, I, M	FP

\*IB is a good alternative where heavy oil carryover is likely.

Designs, materials, weights and performance ratings are approximate and subject to change without notice. Visit [armstronginternational.com](http://armstronginternational.com) for up-to-date information.



# How to Drain Air Distribution Systems

## Installation

The ABCs of trap installation must be followed: “A” for accessible, “B” for below the point being drained, and “C” for close to the point being drained. If the discharge point for this drain trap is some distance away from the drain point, the discharge line from the trap should be run out—not the inlet to the trap.

When installing traps on the drain connection of filters, particular care should be taken to the connection size. Normally outlet connections on filters are 1/4" in size or less. This connection size is normally not large enough to allow anything but slugs of liquid to flow into the trap housing. If a float trap is utilized, it should be either back vented or the connection size must be increased to 3/4" minimum. For additional installation recommendations, see pages LD-51 and LD-52.

Table LD-3. Correction Factors							
For lbs water condensed at temperatures other than 80°F, find wt condensed at 80°F and multiply by factors shown.							
°F	Factor	°F	Factor	°F	Factor	°F	Factor
10	.070	50	.373	100	1.81	140	5.15
20	.112	60	.525	110	2.39	150	6.52
30	.176	70	.729	120	3.12	160	8.19
40	.259	90	1.35	130	4.02	170	10.2

Chart LD-6. Water Condensed From Compressed Air

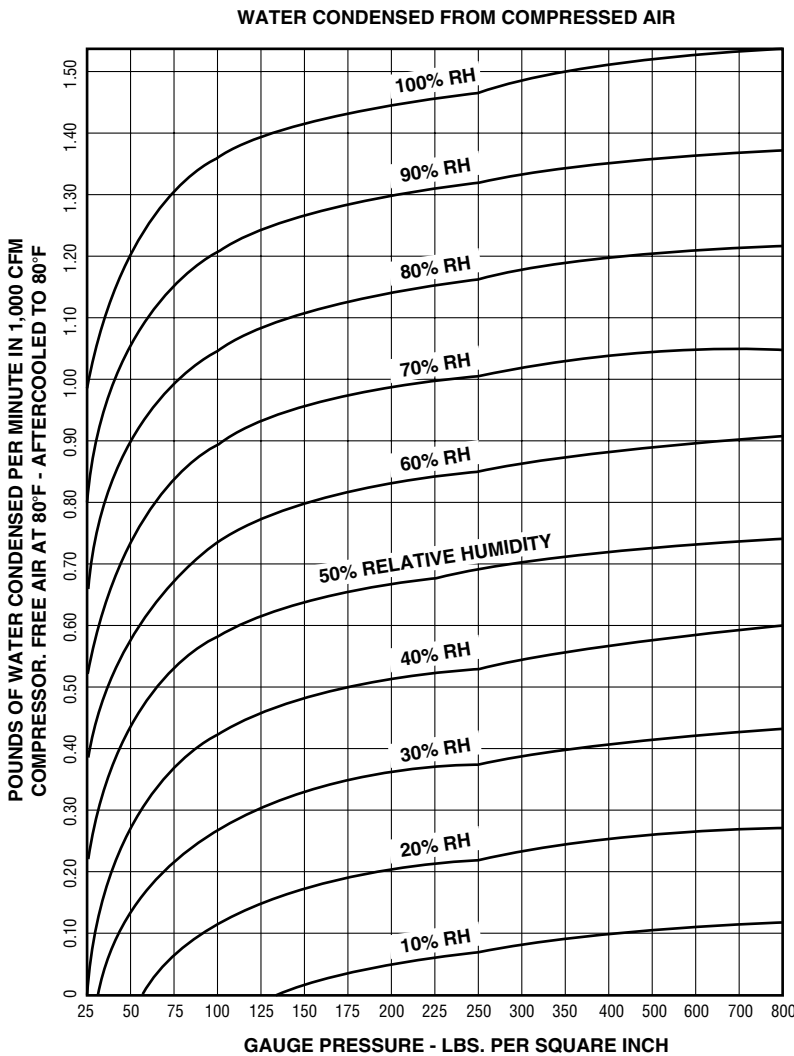

NOTE: Amount of water condensed is in direct ratio to compressor rating. For example, for 500 CFM compressor, multiply determined amount of condensate by 0.50; for 200 CFM compressor, multiply amount of condensate by 0.20.

Liquid Drainers

Designs, materials, weights and performance ratings are approximate and subject to change without notice. Visit [armstronginternational.com](http://armstronginternational.com) for up-to-date information.





# How to Drain Intercoolers, Aftercoolers, and Aftercooler Separator Combinations

## Aftercooler

An aftercooler serves as the primary means of moisture removal on industrial air systems. It increases the efficiency of air distribution by reducing pressure drop created when air flows through the system. It does this by using cooling water to reduce the specific volume of the air which, in turn, allows the air to flow through the system with less pressure drop. Aftercoolers are found on most industrial compressors over 10 hp in size. In addition to removing the heat of compression, aftercoolers also remove approximately two-thirds of the liquid found in the air, and help in the removal and knock-down of oil carryover from the compressor.

## Intercooler

Compressor intercoolers are designed to increase the efficiency of compression by reducing the temperature and specific volume of air between stages of compression. This allows the compressor to do more work at a lower temperature than would normally occur. Because some condensing will occur in the intercooler, a drain trap is required to protect compressor parts.

If liquid were to carry over from the intercooler, it could also carry dirt or scale into the compressor and/or also cause corrosion within the compressor, both of which are undesirable for efficient compressor operation. If slugs of liquid were to pass from the intercooler into the compressor, it would make the compressor operation erratic. Efficient trapping is required at this point to deliver dry air to the next stage of the compressor.

An intercooler is typically a shell and tube heat exchanger. Liquid condensate flow out of the heat exchanger is usually irregular, causing slugs to accumulate and pass into the drain trap. Because of this, a drip leg is required on the

intercooler, and full size outlet piping from the intercooler must be used into a dirt pocket. The drip leg allows the slug of condensate to be handled by the drain trap and handles some small backup while the drain trap is discharging the liquid.

The intercooler may also experience oil carryover if the compressor is not of the oil-less or sealed type. As air enters the intercooler, it carries a mist or tiny droplets of oil along with it. Because the air is at a relatively high temperature, this oil is fairly thin. Then, as the intercooler cools the air and oil, the oil may thicken. The drain trap must be able to discharge this oil before it thickens and negatively affects the drain trap and intercooler operation. Trap selection is very important in this type of application where a water and oil mix must be handled by the trap and the oil must be discharged first.

Since the aftercooler removes approximately two-thirds of the total moisture load, traps here will normally be much larger than those found on the rest of the system.

## Trap Selection and Safety Factor

### Intercooler

Select the proper trap for:

1. Entering water temperature into the intercooler.
2. Airflow rate through the intercooler.
3. Intermediate pressure at which the intercooler is operated.

Use Chart LD-6 on page LD-20, "Water Condensed From Compressed Air," to determine the pounds of water condensed per minute in 1,000 CFM. Then multiply by 60 to convert minutes to hours and use a safety factor of 2:1.

**Chart LD-7. Recommendation Chart**

(See chart on page LD-6 for "Feature Code" references.)

Equipment Being Drained	Air		Gas	
	1st Choice and Feature Code	Alternate Choice	1st Choice and Feature Code	Alternate Choice
Aftercooler	IB F	FF	*FF	FP
Intercooler	, G, J, K, M		B, E, J	

\*Since IBs vent gas to operate, an FF is suggested because gas venting may not be desirable.

Designs, materials, weights and performance ratings are approximate and subject to change without notice. Visit [armstronginternational.com](http://armstronginternational.com) for up-to-date information.

# How to Drain Intercoolers, Aftercoolers, and Aftercooler Separator Combinations



When selecting the type of trap, consider the failure mode and the ability of the trap to respond to slugs of liquid. In most cases, an “open” failure mode will be desirable as it is vital to protect the compressor from slugs of liquid. A quick response to slugs is important so there is no delay between the time the liquid accumulates and the trap discharges the liquid.

## Aftercooler

When the aftercooler condensing rate is not known, there are two typical methods for calculating condensate load. The first method is to calculate total airflow through the system. Then using Chart LD-6 on page LD-20, titled “Water Condensed From Compressed Air,” determine pounds of water condensed per minute in 1,000 CFM. Multiply this by 60 to convert minutes to hours for required trap capacity in pounds per hour (the entering maximum incoming summertime temperature and relative humidity must be known to use this chart). This load is then multiplied by 2 to determine required trap capacity.

The second method of calculating trap capacity is to look at maximum allowable flow rate through the aftercooler. Use the “Water Condensed From Compressed Air” chart on page LD-20 in the same manner as described in Method 1. Although this method will normally yield a larger trap size, it allows for the addition of another compressor or the interconnection of several compressors to the system in the event of unplanned by-passes.

In the second method, it’s important to estimate the average water temperature within the aftercooler as closely as possible. Not all air actually comes in contact with the water tubes; therefore, the air is not uniformly cooled to the water temperature. If actual leaving air temperature is known, this is by far the most accurate figure to use. A properly sized aftercooler will normally cool compressed air down to within 15°F of entering air temperature.

## Installation

When installing drain traps on aftercoolers or aftercooler separator combinations, the “ABCs” of trap installation should be followed:

- Accessible for maintenance and repair.
- Below the point being drained.
- Close to the drip point as possible.

Be sure to follow manufacturer’s instructions on trap installation. Most aftercoolers are equipped with a separate separator. However, if a separator is not furnished, the aftercooler must be trapped individually. In the case of the aftercooler/separator combination, only the separator normally requires a trap. See Fig. LD-18 or LD-19. But again, it is important to follow manufacturer’s instructions. For additional installation recommendations, see pages LD-51 and LD-52.

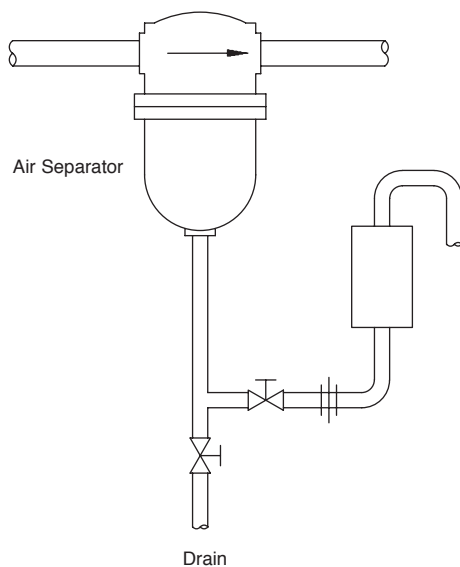

**Figure LD-18.** Installation of a 200 Series inverted bucket drain trap on compressed air contaminated by oil.

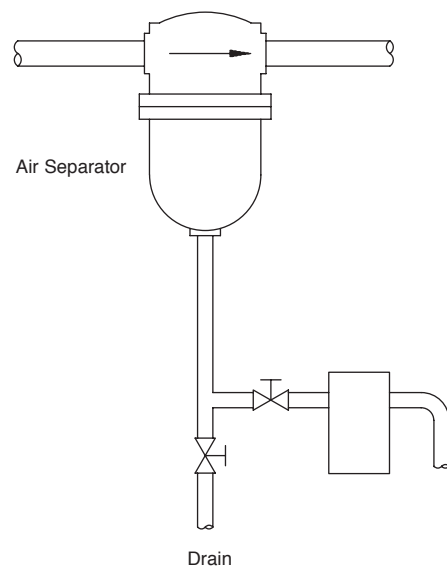

**Figure LD-19.** 800 Series inverted bucket drain trap installed on compressed air contaminated by oil.

Designs, materials, weights and performance ratings are approximate and subject to change without notice. Visit [armstronginternational.com](http://armstronginternational.com) for up-to-date information.



# How to Drain Separators, Separator Filter Combinations

Separators serve an important function within the compressed air system. Separators may also be known as knockout pots, knockout drums or demisters. Their function is to remove liquid that may be moving at a high speed from the flowing air, and they normally perform this function in a two-step process.

1. Separators increase the flow area and volume of the gas, thereby reducing its velocity. Air within the system may flow at velocities exceeding 100 mph. At this velocity any liquid will be entrained as droplets and will not be flowing along the bottom of the pipe. To remove these liquid droplets, it is necessary to reduce the velocity of the gas; otherwise, the droplets accumulate and again become entrained with the flowing gas.
2. The second step is to change direction and impinge the liquid. As the velocity of the gas is reduced, the velocity of the fast-moving droplets can be reduced even further by causing the air to take either 90-degree turns or to centrifugally flow within a chamber. Both of these methods serve to "sling" the droplets up against baffles, plates or the wall of the separator.

Because the droplets have a relatively high mass and are incompressible, their velocity will drop dramatically. At this point, gravity will take over, causing the drops to accumulate and flow into the bottom of the separator. Liquid will often fall in sheets down the wall of the separator and collect at the outlet piping in slugs. The immediate drainage of the slugs is important since the separator is normally a final opportunity to protect an air-using device downstream.

If liquid is allowed to accumulate for any amount of time, it may undermine the entire purpose and function of the separator. Therefore, if the separator does not do its job efficiently, it can actually become a reservoir that accumulates condensate and forms slugs to be transmitted down the air line and into the device being protected. In this case, the use of a separator may be worse than no protection at all.

## Locations

Separators are normally located on the leaving side of aftercoolers and before the compressed air receiver. They are often integral with filters located before sensitive air-using equipment or as part of the filter on a distribution manifold. In this case there may be a combination filter, oiler, regulator and separator drainage point for liquids to accumulate.

## Trap Selection and Safety Factor

If the separator is part of an aftercooler combination installed between the compressor and the receiver, you should refer to the section on Aftercoolers and Aftercooler Separators for trap selection.

Trap selection is fairly critical, especially on equipment with **larger than 1"** air lines feeding it, since slug formation can wash scale into the air-using equipment and become a serious dirt problem. Therefore, on larger than 1" separators, the flow should be **calculated** by totaling the air consumption of the devices downstream and using Chart LD-6, "Water Condensed From Compressed Air," on page LD-20. Use the full water load expected and the safety factor of 3:1 to figure trap capacity.

**Chart LD-8. Recommendation Chart**

(See chart on page LD-6 for "Feature Code" references.)

Equipment Being Drained	1st Choice and Feature Code	Alternate Choice
Separator Line Size > 1"	FF*	IB
Separator Inlet Pipe < 1"	J, B, C, E	FP*

\*IB is a good alternative when heavy oil carryover is likely.

Designs, materials, weights and performance ratings are approximate and subject to change without notice. Visit [armstronginternational.com](http://armstronginternational.com) for up-to-date information.

# How to Drain Separators, Separator Filter Combinations



To determine proper trap capacity for separators with a pipe size of **less than 1"**, the flow can be estimated by using Chart LD-6, "Water Condensed From Compressed Air," on page LD-20, and then calculating 20% of full load.

The safety factor for both selection procedures is 3:1 since separators must respond to surges of liquid from the inlet. In this case, the trap must handle far more liquid than would be experienced under normal operation.

## Installation

When installing ball float type traps on separators 1" and above, it's important to back vent the trap (refer to the section on how to hook up ball floats for the purpose and function of back vent lines, page LD-51). All other types of drainers should be coupled as closely as possible to the drain leg. The drain leg should be the same size as the drain connection on the separator and extend 6" below the separator with another 6" allowed for a dirt pocket. The trap is then tee'd off this line (see Figs. LD-20 and LD-21). This piping is crucial because, as noted above, if the separator does not receive full drainage, it can be worse than no separator at all. For this reason, the "ABCs" are critical:

- A**ccessible for inspection and maintenance.
- B**elow the equipment being drained.
- C**lose to the drain point.

The line size leading from the drip leg to the inlet of the unit should be kept the same size as the trap inlet for good drainage into the trap. Again, when slugs are being handled it's important that the trap begin draining immediately. Back vents on float type traps should be a minimum of 1/2" in pipe size with 3/4" preferred. Any valves used in this back-vent piping should be full ported to allow free gas flow out of and liquid flow into the drain trap. For additional installation recommendations, see pages LD-50 to LD-52.

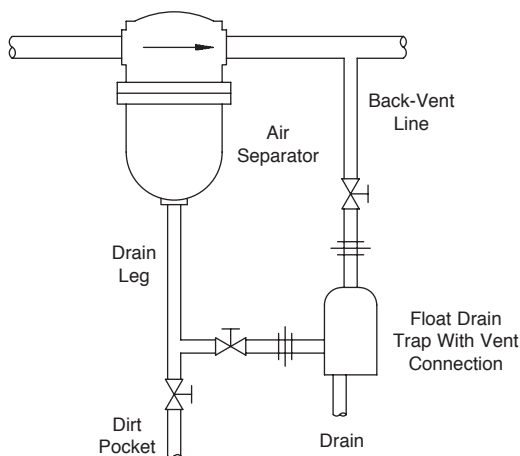

**Figure LD-20.** Installation of a drain trap with equalizing line downstream of the separator in order to assure a quick and regular flow to the drainer. Note side inlet connection from separator.

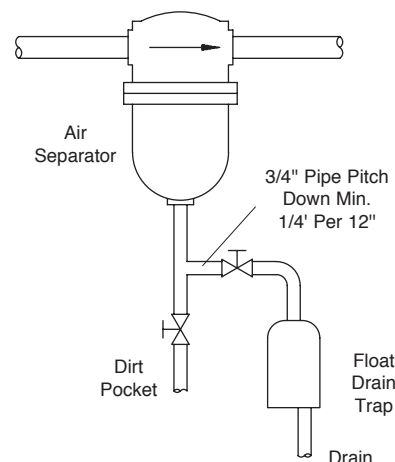

**Figure LD-21.** Installation of a drain trap on side of separator.

Designs, materials, weights and performance ratings are approximate and subject to change without notice. Visit [armstronginternational.com](http://armstronginternational.com) for up-to-date information.



# How to Drain Receivers

Receivers perform the vital function of storing air for the system. The receiver dampens pressure fluctuations in the system and provides a very short storage time in the event of compressor failure. It also functions as a liquid knockout drum to prevent entrained liquid (which may carry over) from entering the compressed air dryer or the air mains. The receiver should be sized to provide enough storage time for an orderly shutdown, particularly in the case of instrumentation air systems. Receiver volume is what provides the amount of air required for storage periods.

The receiver should be located close to the compressor. Fallout of liquid is normal due to low velocity within the receiver. Velocity is at the lowest point it will reach in any other part of the operating system. The air has a high dwell time within the receiver and is more likely to cool to ambient. This cooling of the air is what causes moisture to condense.

The receiver is equipped with a drain port at the bottom to allow liquids to flow to drain traps. In many cases, because receivers are so large and located adjacent to the compressor, they are installed close to the floor. When this happens, the drain point is relatively inaccessible, making trap piping difficult and gravity flow into the trap often impossible. To avoid this, the receiver should be located on a small concrete pad, which will facilitate efficient drain trap installation and operation.

For several reasons, it's good to keep the receiver drained. When receiver volume is lost, the dampening of the compressed air pressure is reduced and the storage time between compressor failure and system shutdown is greatly reduced. Corrosion within the receiver can also take place when liquid is allowed to accumulate.

Manual valves are commonly used to drain receivers since they are typically installed close to the floor. The resulting loss of receiver volume is seldom noticed in the day-to-day operation of the system. However, with any manual system, the valve can be forgotten and not opened. Then, when the weather changes from a relatively dry, low moisture load to a warm, high moisture load, the receiver will lose volume and the dampening effect and accumulator effect are decreased. The compressor can short cycle under these conditions, increasing the wear and tear on the compressor. In addition, the only reminder to open the manual valve is when carryover occurs. In this case, an air dryer can be damaged, liquid can be introduced into the air mains and surge through the system, causing scale to be washed into the system, water hammer and/or freeze damage.

## Trap Selection and Safety Factor

To select the proper trap for the receiver, it is necessary to calculate total system load using Chart LD-6, "Water Condensed From Compressed Air," on page LD-20. Once this total potential load is known, it will be multiplied by the following factors: With an aftercooler, multiply the load by 50%, with an aftercooler separator combination, multiply the total load by 40%, and if no aftercooler is present, multiply the total load by 70%. Once this load is known, a safety factor of 2:1 is applied.

**Table LD-4. Total System Load Multipliers**

Calculate Total System Load with	Aftercooler	Aftercooler Separator	None
Multiply by	50%	40%	70%

**Chart LD-9. Recommendation Chart**

(See chart on page LD-6 for "Feature Code" references.)

Equipment Being Drained	1st Choice and Feature Code	Alternate Choice
Receivers	FS* C, E, I, J, K	IB D

\*FF for over 120 lbs/hr load.

Designs, materials, weights and performance ratings are approximate and subject to change without notice. Visit [armstronginternational.com](http://armstronginternational.com) for up-to-date information.

# How to Drain Receivers

## Installation

When a float type drain trap is used with a receiver, the level will run at about the inlet connection on the trap. Therefore, it is important to locate the trap as close to the floor as feasible and with no dips in the piping. See Figs. LD-22 thru LD-25. If there is a piping dip with a float type unit and the vent connection is not back vented, the unit will fail to operate. In the case of a back-vented unit, the dip in the piping will be flooded at all times. An inverted bucket trap can be installed above floor level since it will operate

above the drain point. An internal check valve, tube and coupling should be installed to prevent the liquid seal from flowing backward on system shutdown. A snap action type float unit should be used when any amount of grit is expected in the system. In this case, the spring life can be extended by moving the drain trap slightly upward to allow liquid to accumulate both within the receiver and within the trap body between trap cycles. For additional installation recommendations, see pages LD-50 to LD-52.

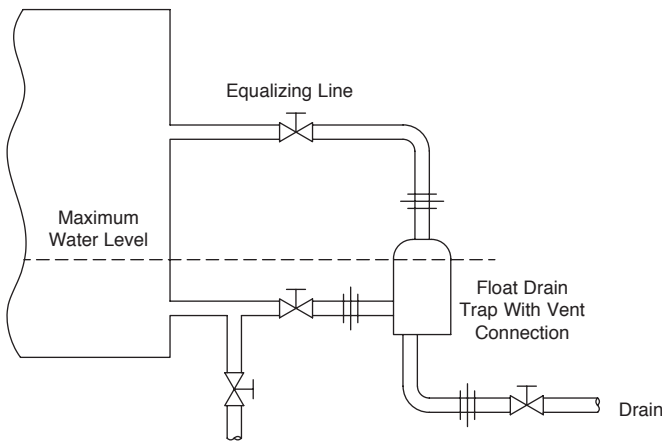

**Figure LD-22.**  
Drain trap installed at side of a receiver, close to floor. Water will rise to broken line before drain trap opens.

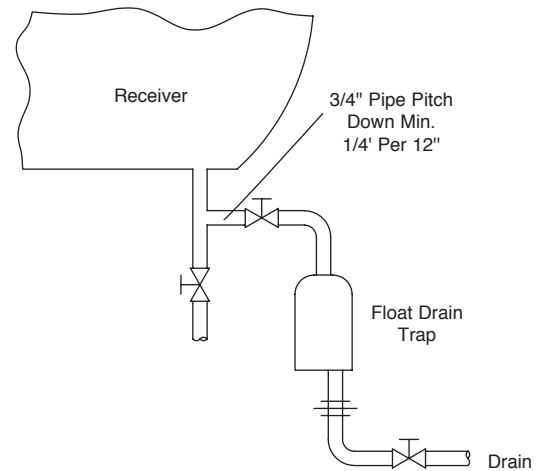

**Figure LD-23.**  
Install the drain trap on side to get better access or compensate for lack of space under the receiver (particularly for drain trap used under compressors).

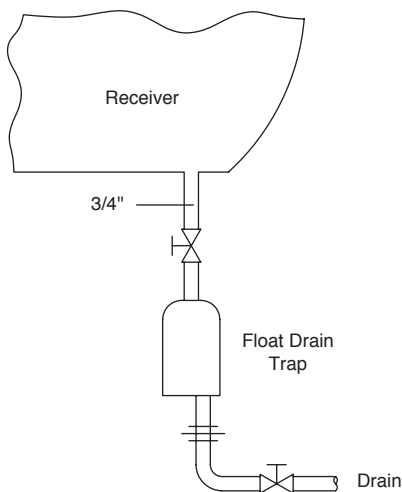

**Figure LD-24.**  
Installation **not recommended** because of the dirt problem that can occur with a drain trap installed straight under the receiver.

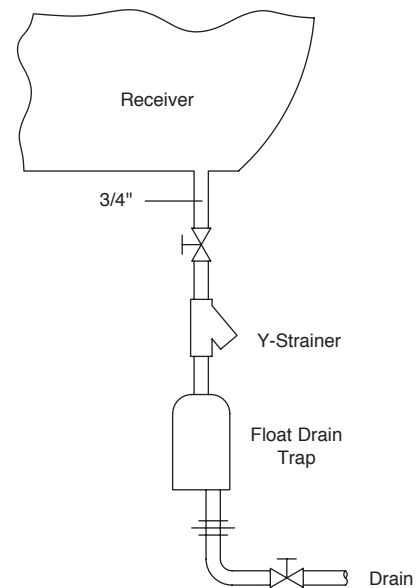

**Figure LD-25.**  
Same installation but with a strainer protecting the drain trap.

Designs, materials, weights and performance ratings are approximate and subject to change without notice. Visit [armstronginternational.com](http://armstronginternational.com) for up-to-date information.

The function of dryers is to eliminate liquid in applications where freezing or any moisture accumulation can cause serious problems with the air-consuming equipment. Dryers should always be installed on instrument quality air systems.

Two basic dryer types are dessicant and refrigerated. In the dessicant type, the dessicant chemical absorbs the liquid by chemically bonding with the water molecules. Dessicant dryers can achieve very low dew points and are often installed with a pre-dryer of the refrigerant type. Refrigerant dryers work the same as aftercoolers by circulating cold fluid, causing the moisture to condense. However, their ability to reach low dew points is limited by the temperature at which frost will form on the heat exchanger tubing (greatly reducing heat transfer).

This leads to a discussion of air dew point. Dew point is the temperature at which moisture will condense out from the air due to its relative humidity increasing above 100%; see Chart LD-11. When this happens, the moisture condenses out and can be drained to a drain trap. Dew point is also important when considering air that has left the dryer, because if the air is ever exposed to temperatures below its dew point, moisture will form. Therefore, when applying air dryers, it is important to consider two features of compressed air usage that will impact dryer selection.

1. When air is compressed, the dew point is increased. Also, the dew point under pressurized conditions must be known. For example, even though a  $-40^{\circ}\text{F}$  dew point is achieved at atmospheric conditions, this becomes a dew point of about  $10^{\circ}\text{F}$  once the air has been compressed to 100 psi. In outdoor systems, when the temperature drops below  $10^{\circ}\text{F}$ , condensing and freezing of that moisture will result.
2. When compressed air is expanded through instruments or air tools, its volume increases, pressure decreases and a temperature drop is usually experienced. If the temperature drops below the dew point of the air, undesirable moisture forms in the equipment. The air would never be subjected to that temperature under any conditions other than when expanding.

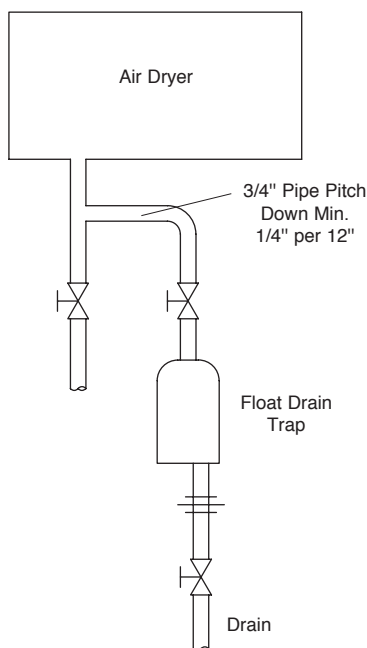

**Figure LD-26.**  
Drain trap installation with dirt leg for purging the dirt.

### Chart LD-10. Recommendation Chart

(See chart on page LD-6 for "Feature Code" references.)

Equipment Being Drained	1st Choice and Feature Code	Alternate Choice
Dryers	FF B, C, J, N	IB FP

Designs, materials, weights and performance ratings are approximate and subject to change without notice. Visit [armstronginternational.com](http://armstronginternational.com) for up-to-date information.



# How to Drain Dryers

Drain traps are usually required on refrigerated type dryers only. Here the refrigerant chills air and creates moisture that the drain trap can discharge. In the case of the desiccant type air dryer, the chemical grabs the moisture and bonds chemically with the water molecules, and no liquid accumulates. These bonded water molecules are then usually driven off in a regeneration cycle the dryer must periodically undergo.

## Trap Selection and Safety Factor

In most cases, the dryer manufacturer will rate the dryer for a given moisture removal rate. The safety factor should still be applied to this load, however. If the manufacturer's ratings are not known, then it's necessary to calculate the moisture content of the air at aftercooler conditions and the moisture content at ambient conditions. Using the lower moisture content between these two, compare that figure to the moisture content at the dew point of the air leaving the dryer. The difference in these moisture contents is then multiplied by the airflow through the dryer to determine the moisture load. The safety factor applied to the load is 2:1 since liquid should be drained immediately from the dryer and the liquid tends to flow into the drain trap in slugs.

## Installation

The dryer should come with a drain port of a given pipe size sufficient to handle the liquid coming out of the dryer. In this pipe size, a drain leg should be piped up 6" below the dryer with another 6" below that as a dirt pocket. Teeing off this line and into the trap with the same inlet size as the trap will allow for gravity drainage into the trap. Again, the ABCs of trap installation should be followed:

- A**ccessible.
- B**elow the point being drained.
- C**lose to the drain leg as possible.

If the trap is too close to the floor to allow the use of a ball float trap, an inverted bucket trap should be considered. For additional installation recommendations, see pages LD-50 to LD-52.

Chart LD-11. Estimated Dew Point of Compressed Air

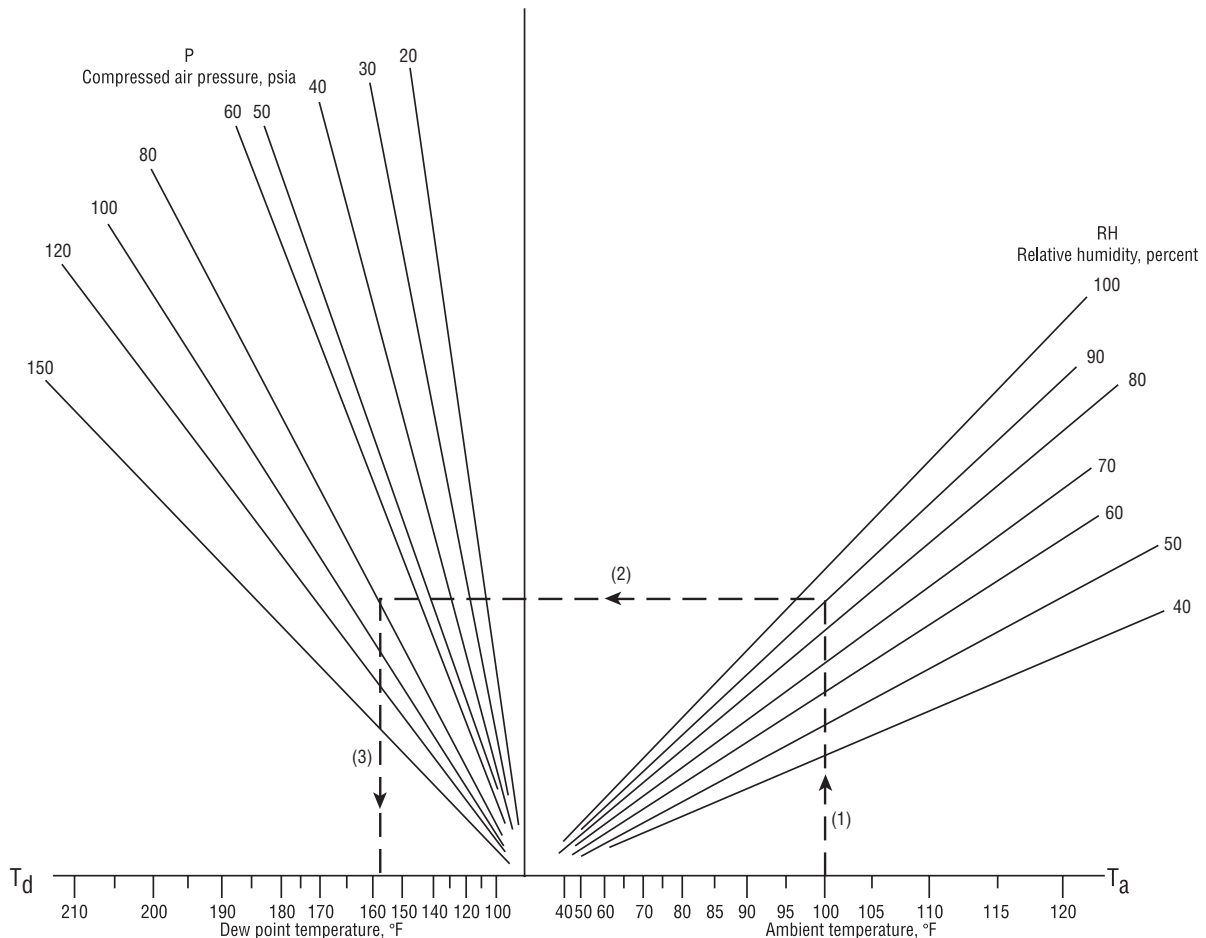

Nomograph estimates dew point of compressed air.

Designs, materials, weights and performance ratings are approximate and subject to change without notice. Visit [armstronginternational.com](http://armstronginternational.com) for up-to-date information.





# How to Select and Size Armstrong Drain Traps

## For Draining Liquids From Gases Under Pressure

Armstrong liquid drain traps are offered in a wide variety of sizes and types to meet the most specific requirements. The most widely used models and sizes utilize bodies, caps and some operating parts that are mass produced for Armstrong steam traps. The proven capabilities of these components, along with volume production economies, enable us to offer you exceptionally high quality at attractive prices. You can choose the smallest and least costly model that will meet your requirements with confidence.

### Selection Procedure for Draining Liquid From Gas

1. Multiply the actual peak liquid load (lbs/hr) by a safety factor of at least 1-1/2 or 2. See paragraph headed "Safety Factors."
2. From Orifice Capacity Chart LD-12, find the orifice size that will deliver the required cold water capacity at the maximum operating pressure. If a light liquid is to be drained, convert light liquid capacity in lbs per hour to water capacity using factors in Table LD-5. Then find orifice size from Chart LD-12.
3. From the Orifice Size Operating Pressure tables on the product model pages, find the drain trap(s) capable of opening the required orifice size at a specific pressure (and specific gravity if other than cold water—specific gravity 1.0).

**NOTE:** If specific gravity falls between those shown in the tables, use next lower. Example: If specific gravity is 0.73, use 0.70 gravity data.

### Safety Factors

Safety factor is the ratio between actual continuous discharge capacity of the drain trap and the amount of liquid to be discharged during any given period. Chart LD-12 shows the maximum continuous rate of cold water discharge of the drain trap. However, you must provide capacity for peak loads and, possibly, lower-than-normal pressures. A safety factor of 1-1/2 or 2 is generally adequate if applied to the peak load and the minimum pressure at which it occurs. If the load discharge to the trap is sporadic, a higher safety factor may be required. Contact your Armstrong Representative for details.

### Selection Examples

**EXAMPLE No. 1:** Find a drain trap to drain 1,000 lbs of water per hour from air at 500 psi pressure differential.

Multiply 1,000 lbs/hr by 2 (if not already done) to provide a safety factor; thus, a 2,000 lbs/hr continuous discharge capacity is required. In Capacity Chart LD-12, the 2,000 lb capacity line intersects the 500 psi pressure line directly below the No. 38 drill orifice curve. This orifice is available in the No. 1-LD or No. 11-LD drain trap, but for much lower pressures. Moving to the 32-LD, a #38 orifice is good to 489 psi. This is the trap/orifice combination to use.

Table LD-14, page LD-37, shows the No. 32-LD drain trap with #38 orifice will operate at pressures up to 489 psi and, therefore, is suitable for the job. Further checking shows the No. 2313 HLS drain trap with a 7/64" orifice could also handle the job, but it is designed particularly for low gravity liquids and is more costly than the No. 32-LD, so the No. 32-LD is a better choice.

**EXAMPLE No. 2:** Find a drain trap to drain 6,400 lbs/hr (safety factor included) of .80 specific gravity liquid from gas at 400 psi pressure differential.

Since Capacity Chart LD-12 is based on water capacity, the known light liquid capacity requirement must be converted to its equivalent water capacity with the factor given in Table LD-5:  $6,400 \times 1.12 = 7,168$  = water capacity required for using Chart LD-12.

Chart LD-12 shows that 7,168 lbs/hr and 400 psig calls for a 7/32" orifice. Entering the .80 specific gravity column of Table LD-14, page LD-37, shows that a No. 36-LD forged steel drain trap will open a 7/32" orifice at pressures up to 707 psi. As a matter of fact, this drain trap will open a 1/4" orifice at 501 psi and would be the one to use.

**NOTE:** While drain traps are sized on the basis of pressure differential, steel must be used whenever gauge pressure in the drain trap exceeds 250 psig.

### Where Not to Use

Float type drain traps are *not* recommended where heavy oil, sludge or considerable dirt are encountered in lines. Dirt can prevent the valve from seating tightly, and cold oil can prevent float traps from opening. Where these conditions exist, Armstrong inverted bucket BSW traps should be used.

### How to Order Drain Traps

Specify:

- Drain trap size by number
- Orifice size
- Pipe connections—size and type
- Maximum operating pressure

If the correct drain trap cannot be determined, tell us capacity required, maximum pressure, and SPECIFIC GRAVITY of liquid.

**Table LD-5. Conversion Factors to Find Cold Water Capacity Equivalents for Light Liquids**

Specific Gravity	Multiply Light Liquid Capacity in Pounds Per Hour by:
.95	1.03
.90	1.06
<b>.85</b>	<b>1.09</b>
.80	1.12
.75	1.16
<b>.70</b>	<b>1.20</b>
.65	1.24
.60	1.29
<b>.55</b>	<b>1.35</b>
.50	1.42
.45	1.49
.40	1.58

Designs, materials, weights and performance ratings are approximate and subject to change without notice. Visit [armstronginternational.com](http://armstronginternational.com) for up-to-date information.

# How to Select and Size Armstrong Drain Traps

## For Draining Water From a Light Liquid

Armstrong dual gravity drain traps for draining water from a light liquid are described on pages LD-47 and LD-48. All models shown are identical to corresponding models of traps used to drain liquid from a gas except that float weights are modified to make them suitable for draining water from a light liquid.

Dual gravity drain trap\* selection requires that you know the peak heavy liquid load, maximum operating pressure, and specific gravity of the light liquid. With this information you can determine the orifice size required from Chart LD-12 and find the specific drain trap that will meet your conditions from the pressure tables on the dual gravity pages.

### Selection Procedure for Draining Water from a Light Liquid

1. Assume a required safety factor of 2:1. Multiply the peak load in pounds per hour by 2. (See paragraph on "Safety Factors.")
2. From Capacity Chart LD-12, find the intersection of actual load times safety factor and the minimum operating pressure differential. Follow the pressure line immediately above this point to intersect the next higher orifice capacity curve. Then follow this curve downward and to the left to get the orifice size.
3. Inspect the tables on pages LD-47 and LD-48 to find the smallest trap that can open the predetermined orifice size at the maximum operating pressure differential. Do not oversize dual gravity drain traps. Oversizing will cause excessive fluctuation of the interface between the two liquids.

**NOTE:** While drain traps are sized on the basis of operating pressure differential, forged steel must be used when total pressure in the drain trap exceeds 250 psig.

## How to Order Dual Gravity Drain Traps

Specify:

- Drain trap size by number
- Orifice size
- Pipe connections—size and type
- Specific gravity of light liquid
- Weight of water discharge per hour
- Maximum operating pressure

If you are not sure of the drain trap size to use, then specify:

- Specific gravity of light liquid
- Capacity in pounds of water per hour with safety factor included
- Working pressure—maximum and minimum

**Chart LD-12.**

**Calculated Cold Water Capacity of Armstrong Drain Trap Orifices at Various Pressures**  
Actual capacity also depends on trap configuration, piping and flow to trap. It is important to allow for safety factors and fluid density variations due to temperature.

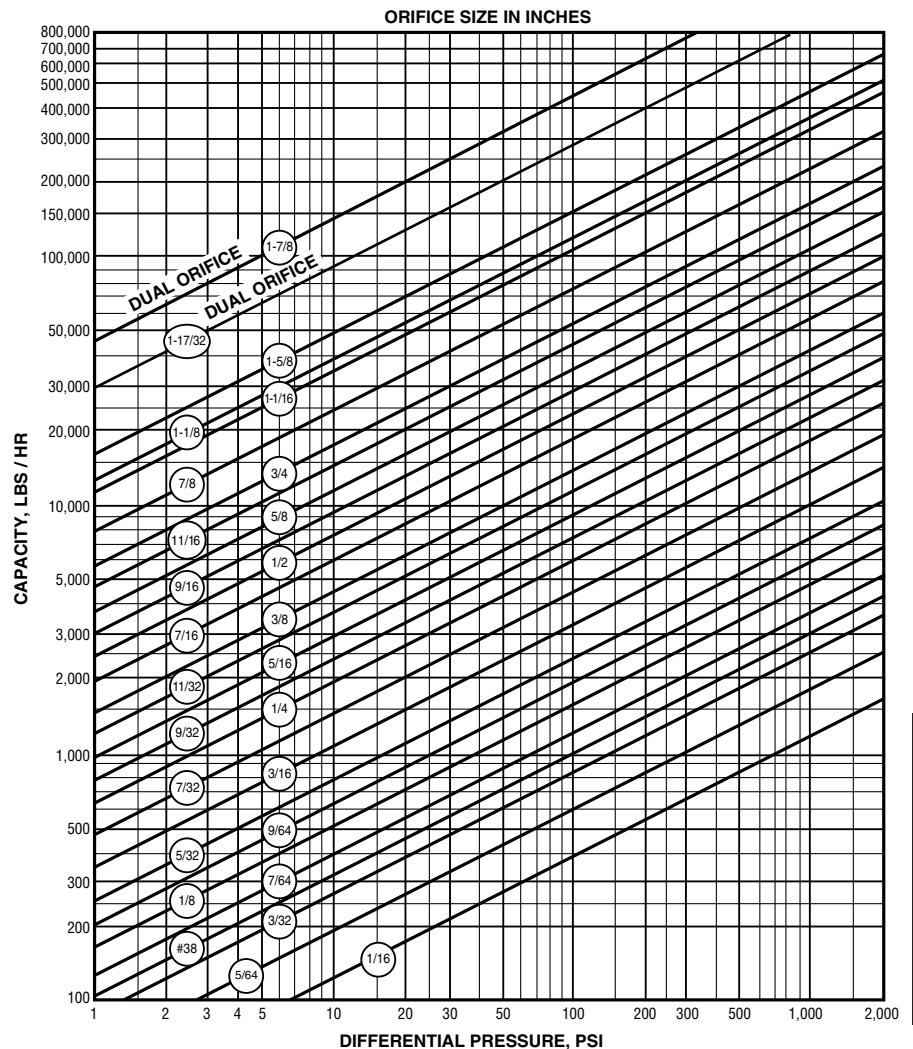

\* Floats for dual gravity drain traps are weighted with quenching oil which, in the unlikely possibility of float failure, may be dispersed through the system. If this is a hazard, consult the Armstrong Application Engineering Department.

Designs, materials, weights and performance ratings are approximate and subject to change without notice. Visit [armstronginternational.com](http://armstronginternational.com) for up-to-date information.