



Steam Traps

Inverted bucket, float and thermostatic, thermostatic and controlled disc steam traps in carbon steel, stainless steel, forged steel and cast iron.



Armstrong

Bringing Energy Down to Earth

Say energy. Think environment.

And vice versa.

Any company that is energy conscious is also environmentally conscious. Less energy consumed means less waste, fewer emissions and a healthier environment.

In short, bringing energy and environment together lowers the cost industry must pay for both. By helping companies manage energy, Armstrong products and services are also helping to protect the environment.

Armstrong has been sharing know-how since we invented the energy-efficient inverted bucket steam trap in 1911. In the years since, customers' savings have proven again and again that knowledge *not* shared is energy wasted.

Table of Contents

Inverted Bucket Steam Trap Introduction	6
Cast Iron Inverted Bucket Steam Traps	8
Forged Steel Inverted Bucket Steam Traps	10
Capacity Chart for Inverted Bucket Traps	12
Series 2010 Stainless Steel Inverted Bucket Steam Traps	14
Series 1810 Stainless Steel Inverted Bucket Steam Traps	16
Series 1010 and U-1010 Stainless Steel Inverted Bucket Steam Traps	18
Cast Steel Inverted Bucket Steam Traps	20
Automatic Differential Condensate Controllers	22
Float and Thermostatic Steam Trap Introduction	24
A&B Series Float and Thermostatic Steam Traps	26
Ultra-Capacity Float and Thermostatic Steam Traps	28
Thermostatic Wafer Traps	30
Balanced Pressure Bellows Traps	31
Radiator Traps	33
Controlled Disc Steam Traps	34
Capacities and Physical Data for Armstrong Steam Traps in Metric Units	35

Abbreviated Trap Selection and How to Order

This section only highlights the complete trap selection information available in the Armstrong Steam Conservation Guidelines for Condensate Drainage, Handbook N-101. Armstrong's Software Program 1 (Steam Trap Sizing and Selection) is designed to be used in conjunction with Handbook N-101 and this catalog. If you do not have Handbook N-101 or your free copy of Software Program 1, contact your Armstrong Representative.

Actual installation and operation of steam trapping equipment should be performed only by experienced personnel. Selection or installation should always be accompanied by competent technical assistance or advice. This catalog or its accompanying handbook should never be used as a substitute for such technical advice or assistance. We encourage you to contact Armstrong or its local representative for further details.

Basic Considerations

Unit trapping is the use of a separate steam trap on each condensing unit including, whenever possible, each separate chest or coil of a single machine.

You'll select most traps with the aid of past experience. Either yours, the know-how of your Armstrong Representative/Distributor or what others have learned in trapping similar equipment.

Do-it-yourself sizing is simple with the aid of Armstrong Software Program 1. Even if you don't have access to this computer program, trap sizing is easy when you know or can figure:

1. Condensate loads in lbs/hr.
2. The safety factor to use.
3. Pressure differential.
4. Maximum allowable pressure.

Safety Factor or Experience Factor

Steam mains. Select traps to discharge condensate produced by radiation losses.

Traps installed between the boiler and the end of the steam main: 2:1.

Traps installed at the end of the main or ahead of reducing and shutoff valves that are closed part of the time: 3:1.

Steam tracer lines. On most tracer line applications, the flow to the steam trap is surprisingly low. Therefore, the smallest trap is normally adequate.

Process equipment. Different application requirements involving constant or variable steam pressure determine which type of trap should be used. The safety factor is dependent upon the type of equipment being drained and the pressure.

I. Constant Steam Pressure

A 2:1 or a 3:1 safety factor at operating pressure differentials.

II. Modulating Steam Pressure

A. F&T traps and inverted bucket traps with thermic buckets.

1. 0-15 psig steam—2:1 at .5 psi pressure differential. (On F&T traps SHEMA ratings can also be used.)

2. 16-30 psig steam—2:1 at 2 psi pressure differential.

3. Above 30 psig steam—3:1 at 1/2 of maximum pressure differential across the trap.

B. Inverted bucket traps without thermic buckets. Above 30 psig steam pressure only—3:1 at .5 of maximum pressure differential across the trap.

Trap application assistance

is one of the most important parts of the complete trap service provided by Armstrong International. Armstrong Representatives are qualified by factory training and extensive field experience to assist you in any trapping problem. Backing the representatives are Armstrong trapping specialists who are available to assist with especially difficult or unusual requirements.

How to Order

1. Specify model number.
2. Specify size of pipe connection. When flanges are required, specify type of flange in detail.
3. Specify maximum working pressure that will be encountered.
4. Specify orifice size.
5. Specify any options required.

Table 5-1. How Various Types of Steam Traps Meet Specific Operating Requirements

Feature Code	Characteristic	Inverted Bucket	F&T	Disc	Thermostatic	Differential Controller
A	Method of Operation	(1) Intermittent	Continuous	Intermittent	(2) Intermittent	Continuous
B	Energy Conservation (Time in Service)	Excellent	Good	Poor	Fair	(3) Excellent
C	Resistance to Wear	Excellent	Good	Poor	Fair	Excellent
D	Corrosion Resistance	Excellent	Good	Excellent	Good	Excellent
E	Resistance to Hydraulic Shock	Excellent	Poor	Excellent	(4) Poor	Excellent
F	Vents Air and CO ₂ at Steam Temperature	Yes	No	No	No	Yes
G	Ability to Vent Air at Very Low Pressure (1/4 psig)	Poor	Excellent	(5) NR	Good	Excellent
H	Ability to Handle Start-up Air Loads	Fair	Excellent	Poor	Excellent	Excellent
I	Operation Against Back Pressure	Excellent	Excellent	Poor	Excellent	Excellent
J	Resistance to Damage from Freezing (6)	Good	Poor	Good	Good	Good
K	Ability to Purge System	Excellent	Fair	Excellent	Good	Excellent
L	Performance on Very Light Loads	Excellent	Excellent	Poor	Excellent	Excellent
M	Responsiveness to Slugs of Condensate	Immediate	Immediate	Delayed	Delayed	Immediate
N	Ability to Handle Dirt	Excellent	Poor	Poor	Fair	Excellent
O	Comparative Physical Size	(7) Large	Large	Small	Small	Large
P	Ability to Handle "Flash Steam"	Fair	Poor	Poor	Poor	Excellent
Q	Mechanical Failure (Open - Closed)	Open	Closed	(8) Open	(9)	Open

1. Condensate drainage is continuous, discharge is intermittent.
2. Can be continuous on low load.
3. Excellent when "secondary steam" is utilized.

4. Bimetallic and wafer traps—good.
5. Not recommended for low pressure operations.
6. Cast iron traps not recommended.
7. In welded stainless steel construction—medium.

8. Can fail closed due to dirt.
9. Can fail either open or closed depending upon the design of the bellows.



The Inverted Bucket Steam Trap

Energy Efficient Because It's So Reliable

The inverted bucket is the most reliable steam trap operating principle known. The heart of its simple design is a unique leverage system that multiplies the force provided by the bucket to open the valve against pressure. Since the bucket is open at the bottom, it resists damage from water hammer, and wearing points are heavily reinforced for long life.

The inverted bucket has only two moving parts—the valve lever assembly and the bucket. That means no fixed points, no complicated linkages. Nothing to stick, bind or clog.

Conserves Energy Even in the Presence of Wear

Armstrong inverted bucket steam traps open and close based on the difference in density between condensate and steam—the inverted bucket principle. They open and close gently, minimizing wear. This simple fact means that inverted buckets are subject to less wear than some other types of traps.

In fact, as an Armstrong inverted bucket trap wears, its tight seal actually *improves*. The ball valve and seat of the Armstrong trap provide essentially line contact—resulting in a tight seal because the entire closing force is concentrated on one narrow seating ring.

An Armstrong inverted bucket trap continues to operate efficiently with use. Gradual wear slightly increases the diameter of the ball valve. But the more it wears, the tighter the seal. The ball valve seats itself deeper as wear increases, preserving a tight seal.

Corrosion-Resistant Parts

The stainless steel valve and seat of the Armstrong inverted bucket steam trap are individually ground and lapped together in matched sets. All other working parts are wear- and corrosion-resistant stainless steel.

Venting of Air and CO₂

The Armstrong inverted bucket provides continuous automatic air and CO₂ venting with no cooling lag or threat of air binding.

Operation Against Back Pressure

The Armstrong inverted bucket has excellent performance against back pressure. It has no adverse effect on inverted bucket operation other than to reduce its capacity by the low differential. The bucket simply requires less force to pull the valve open and cycle the trap.

Freedom From Dirt Problems

Armstrong designed its inverted bucket to be virtually free of dirt problems. The valve and seat are at the top of the trap, far away from the larger particles of dirt which fall to the bottom. Here the up-and-down action of the bucket pulverizes them. Since the valve of an inverted bucket is either fully closed or open, dirt particles pass freely. And the swift flow of condensate from under the bucket's edge creates a unique self-scrubbing action that sweeps dirt out of the trap.

Figure 6-1. Armstrong IB Valve Seating/Ball Valve

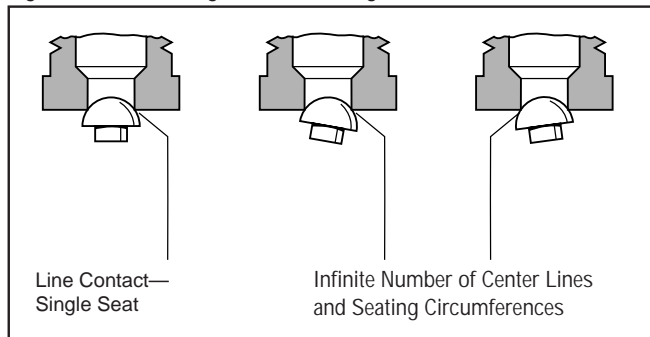

Figure 6-2. IB Valve Wear Characteristics

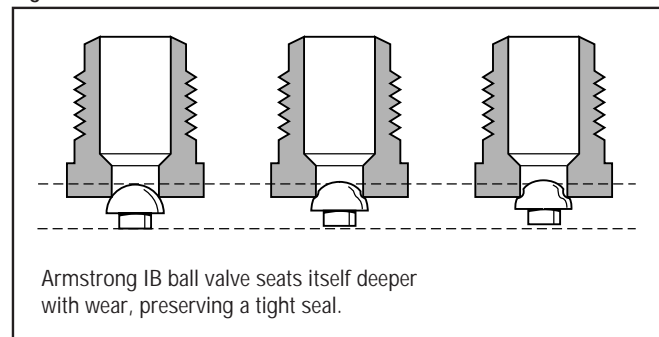
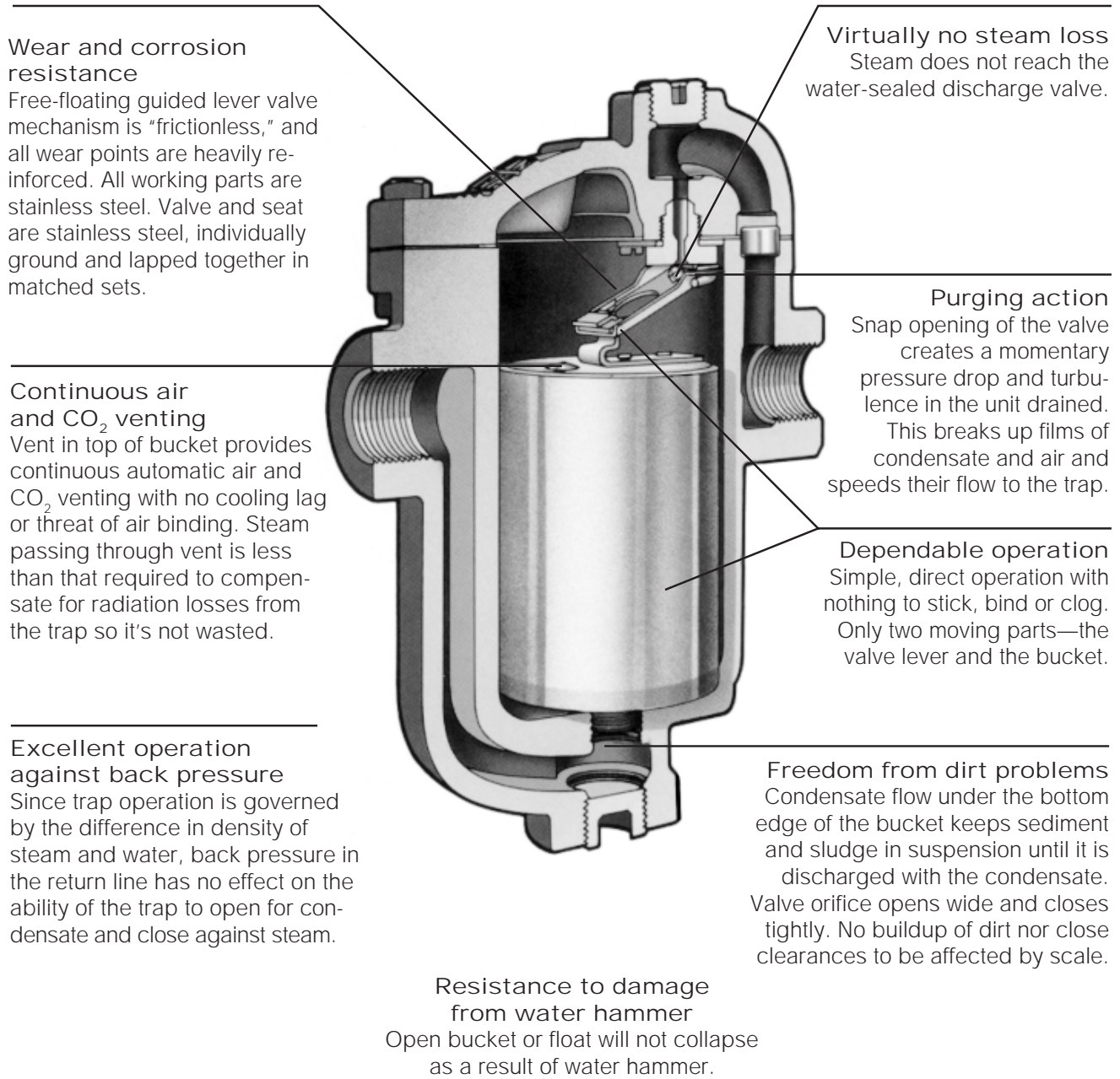

Figure 7-1. Armstrong Inverted Bucket Design



Cast Iron Inverted Bucket Traps

For pressures to 250 psig...capacities to 20,000 lbs/hr

The most reliable steam trap operating principle known—the inverted bucket—provides efficient condensate drainage of virtually all types of steam-using equipment. Put that principle to work in a tough cast iron package,

and you have the best of both worlds. Because they operate more efficiently longer, Armstrong cast iron inverted buckets add solid energy savings to lower replacement/labor costs. All Armstrong cast iron inverted

bucket steam traps are completely repairable, and you can renew side inlet/side outlet models in-line for even bigger maintenance savings.

Capacities

Table 8-1. Series 800, 880 and 200 Traps

Differential Pressure, psi	Orifice Size	Model 800	Orifice Size	Model 811, 881	Orifice Size	Model 812, 882	Orifice Size	Model 813, 883	Orifice Size	Model 814	Orifice Size	Model 815	Orifice Size	Model 816
		880		211		212		213		214		215		216
1/4	↑	139	↑	191	↑	350	↑	950	↑	1,400	↑	2,050	↑	4,050
1/2	↑	200	↑	300	↑	570	↑	1,410	↑	2,160	↑	3,100	↑	6,240
3/4	↑	240	↑	395	↑	740	↑	1,618	↑	2,600	↑	3,740	↑	7,510
1	↑	270	↑	450	↑	850	↑	1,880	↑	2,900	↑	4,160	↑	8,400
2	↑	340	↑	590	↑	1,140	↑	2,300	↑	3,700	↑	5,400	↑	10,700
3	↑	390	↑	680	↑	1,320	↑	2,600	↑	4,150	↑	6,200	↑	12,000
4	↑	425	↑	750	↑	1,480	↑	2,780	↑	4,500	↑	6,800	↑	13,000
5	↑	450	↑	830	↑	1,600	↑	2,900	↑	4,800	↑	7,600	↑	14,500
10	↑	560	↑	950	↑	1,900	↑	3,500	↑	5,800	↑	9,000	↑	17,300
15	↑	640	1/4"	1,060	5/16"	2,100	1/2"	3,900	5/8"	6,500	3/4"	10,000	1 1/16"	19,200
20	3/16"	690	↑	880	↑	1,800	↑	3,500	↑	6,000	↑	8,500	↑	18,500
25	↑	460	↑	950	↑	1,900	↑	3,800	↑	6,500	↑	9,200	↑	20,000
30	↑	500	3/16"	1,000	1/4"	2,050	3/8"	4,000	1/2"	6,800	9/16"	9,800	↑	18,000
40	↑	550	↑	770	↑	1,700	↑	3,800	↑	5,800	↑	8,300	↑	20,000
50	↑	580	↑	840	↑	1,900	↑	4,100	↑	6,300	↑	9,000	↑	18,200
60	↑	635	↑	900	↑	2,000	5/16"	4,400	3/8"	6,800	7/16"	9,500	↑	19,800
70	↑	660	5/32"	950	3/16"	2,200	↑	3,800	↑	6,000	↑	9,200	↑	18,300
80	1/8"	690	↑	800	↑	1,650	9/32"	4,000	↑	6,400	↑	9,700	↑	19,000
100	↑	640	↑	860	↑	1,800	↑	3,600	↑	6,200	3/8"	10,400	↑	18,000
125	7/64"	680	1/8"	950	5/32"	2,000	1/4"	3,900	5/16"	6,700	↑	10,900	↑	20,000
130	↑	550	↑	780	↑	1,410	↑	3,300	↑	5,500	↑	11,000	↑	17,900
150	#38	570	↑	810	↑	1,500	↑	3,500	↑	5,700	↑	9,500	↑	18,500
180	—	—	↑	850	↑	1,560	7/32"	3,700	9/32"	6,000	5/16"	10,000	7/16"	20,000
200	—	—	7/64"	860	1/8"	1,600	↑	3,200	↑	5,300	↑	9,200	↑	17,500
225	—	—	↑	730	↑	1,280	↑	3,400	↑	5,500	9/32"	9,800	↑	18,500
250	—	—	#38	760	7/64"	1,300	3/16"	3,500	1/4"	5,700	1/4"	7,000	3/8"	19,000

Capacities given are continuous discharge capacities in pounds of hot condensate per hour at differential indicated. For complete trap capacities, refer to page 12.

NOTE: Cast iron traps should not be used in systems where excessive hydraulic and thermal shock are present.

List of Materials

Table 8-2. Series 800, 880 and 200 Traps

Name of Part	Material
Cap and Body	ASTM A 48 Class 30
Inlet Tube	Steel Pipe
Gasket	Compressed Non-asbestos
Bolt and Nut Set	No. 800, 880, 811, 881 traps SAE Grade 5. All others SAE Grade 2.
No. 815 & 816 Bolt Set	ASTM A 193 Grade B7
No. 815 Nut Set	ASTM A 563 Grade A
No. 816 Nut Set	ASTM A 194 Grade 2H
Valve & Valve Seat	Stainless Steel
Valve Retainer	Stainless Steel
Lever	Stainless Steel
Guide Pin Assembly	Stainless Steel
Bucket	Stainless Steel, Nos. 214, 814, and larger buckets have cast iron weights.
Body Thimble*	Stainless Steel
880 Series	
Integral Strainer	Stainless Steel
Bushing	Steel
Strainer Bushing Gasket	Soft Steel

*Models 815, 816 and Series 200 do not have Body Thimbles.

Options

Internal Check Valves are spring loaded stainless steel and screw directly into the trap inlet or into an extended inlet tube having a pipe coupling at the top to save fittings, labor and money. See Fig. 8-1.

Thermic Vent Buckets have a bi-metal controlled auxiliary air vent for discharging large amounts of air on start-up. Suitable for pressures up to 250 psig. See Fig. 8-1.

Cast 316 Stainless Steel Bodies and all stainless steel internals are available on Models 211, 212, 213 and 216 traps.

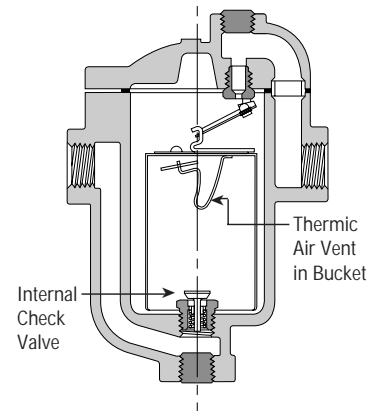

Figure 8-1.

Trap with internal check valve installed directly into trap inlet and thermic vent in bucket.

NOTE: Internal check valves may result in slightly reduced trap capacities.



Model 816.
Handles capacities to 20,000 lbs/hr



Physical Data

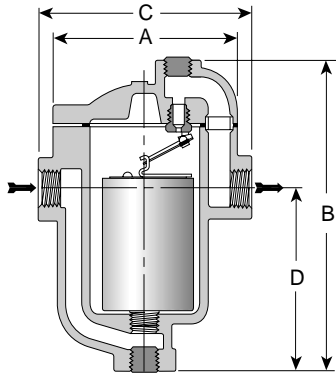

Figure 9-1. Series 800 Traps

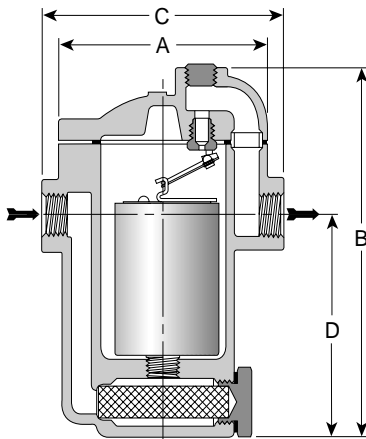

Figure 9-2. Series 880 Traps

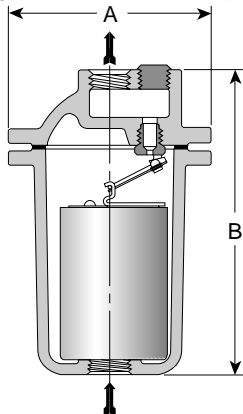

Figure 9-3. Series 200 Traps

Table 9-1. Series 800, Side Inlet, Side Outlet Traps

Add suffix "CV" to model number for internal check valve, "T" for thermic vent bucket.

Model No.	800*	811	812	813	814	815	816
Pipe Connections	1/2", 3/4"	1/2", 3/4", 1"	1/4", 3/4"	3/4", 1"	1/2", 3/4", 1"	1", 1 1/4", 1 1/2", 2"	2", 2 1/4"
Test Plug (in)	1/4	1/4	1/2	3/4	1	1 1/2"	2
"A" (Flange Diameter) (in)	3 3/4	3 3/4	5 5/8	7	8	9	11 1/2"
"B" (Height) (in)	5 7/8	6 7/8	9 1/16	11 3/4	13 5/8	16 1/4"	21 5/16"
"C" (Face-to-Face) (in)	5	5	6 1/2	7 3/4	9	10 1/4"	13
"D" (Bottom to C _L Inlet) (in)	2 3/4	4 1/4	5 3/8	7 1/32	7 13/16	8 1/16"	11
Number of Bolts	6	6	6	6	8	8	8
Weight (lbs)	5	6	15	27 1/2	44	71	131
Maximum Allowable Pressure (Vessel Design) @ 450°F	250 psig	250 psig	250 psig	250 psig	250 psig	250 psig	250 psig
Max. Operating Pressure (psi)	150	250	250	250	250	250	250

*Cannot be furnished with both thermic vent bucket and check valve.

Table 9-2. Series 880, Side Inlet, Side Outlet Traps With Integral Strainers

Add suffix "CV" to model number for internal check valve, "T" for thermic vent bucket.

Model No.	880*	881	882	883
Pipe Connections	1/2", 3/4"	1/2", 3/4", 1"	1/2", 3/4"	3/4", 1", 1 1/4"
Test Plug (in)	1/4	1/4	1/2	3/4
"A" (Flange Diameter) (in)	3 3/4	3 3/4	5 5/8	7
"B" (Height) (in)	6 1/16	7 1/16	9 3/8	12 3/8
"C" (Face-to-Face) (in)	5	5	6 1/2	7 7/8
"D" (Bottom to C _L Inlet) (in)	3 7/16	4 7/16	5 3/4	7 3/8
Number of Bolts	6	6	6	6
Weight (lbs)	5 1/2	6	15 1/2	31
Maximum Allowable Pressure (Vessel Design) @ 450°F	250 psig	250 psig	250 psig	250 psig
Maximum Operating Pressure (psi)	150	250	250	250

*Cannot be furnished with both thermic vent bucket and check valve.

Table 9-3. Series 200, Bottom Inlet, Top Outlet Traps

Add suffix "CV" to model number for internal check valve, "T" for thermic vent bucket.

Model No.	211	212	213	214	215	216
Pipe Connections	1/2"	1/2", 3/4"	1/2", 3/4", 1"	1", 1 1/4"	1", 1 1/4", 1 1/2"	1 1/2", 2"
Test Plug (in)	1/8	3/8	1/2	1/2	3/4	1
"A" (Flange Diameter) (in)	4 1/4	5 1/4	6 3/8	7 1/2	8 1/2	10 3/16
"B" (Height) (in)	6 3/8	8	10 3/4	12 1/2	14 5/16	17
Number of Bolts	6	8	6	8	8	12
Weight (lbs)	6	11 1/2	20 1/4	33	44 3/4	77 1/2
Maximum Allowable Pressure (Vessel Design) @ 450°F	250 psig	250 psig	250 psig	250 psig	250 psig	250 psig
Max. Oper. Pressure (psi)	250	250	250	250	250	250

All dimensions and weights are approximate. Use certified print for exact dimensions.

Forged Steel Inverted Bucket Traps

For pressures to 2,700 psig...capacities to 19,000 lbs/hr

Operation on superheat. A normally operating bucket trap is filled with saturated steam and condensate. Superheated steam can enter only as fast as the steam inside can condense. As a result, the temperature of the trap is at (or slightly below)

saturated steam temperature, regardless of the degree of superheat.

Trap selection. The pressure-containing parts of the steam trap should safely withstand the maximum

pressure and temperature conditions of the system. For example, a trap is required for a 1,000 psig main at 950°F. The normal operating temperature of the trap will be about 546°F. A Model 5133G trap should be selected (see Table 10-2) even

Capacities

Table 10-1. Series 300 and 400 Traps

Diff. Press., psi	Orifice Size	Model 310 310FW	Orifice Size	Model 312 312FW	Orifice Size	Model 313 313FW	Orifice Size	Model 314 314FW	Orifice Size	Model 315 315FW	Orifice Size	Model 316 316FW	Orifice Size	Model 411G, 411G-FW 421, 421-FW	Orifice Size	Model 413 413FW	Orifice Size	Model 415 415FW	Orifice Size	Model 416 416FW
250	#38	760	↑	1,775	3/16"	3,500	1/4"	5,800	↑	7,000	3/8"	19,000	↑	875	3/16"	3,500	↑	7,000	3/8"	19,000
300	↑	510	↑	1,900	↑	2,700	↑	4,950	7,500	↑	16,000	↑	950	↑	2,700	↑	7,500	↑	16,000	
350	↑	550	↑	2,000	↑	2,900	↑	5,100	1/4"	8,000	↑	17,000	↑	1,000	↑	2,900	1/4"	8,000	↑	17,000
370	↑	570	↑	2,100	↑	3,000	7/32"	5,300	↑	6,500	11/32"	17,200	↑	1,025	↑	3,000	↑	6,500	11/32"	17,200
400	5/64"	590	↑	2,200	↑	3,100	↑	4,000	↑	6,900	↑	14,000	↑	1,050	↑	3,100	↑	6,900	↑	14,000
450	↑	—	1/8"	2,400	5/32"	3,200	↑	4,200	↑	7,100	↑	14,500	↑	1,125	5/32"	3,200	↑	7,100	↑	14,500
500	↑	—	↑	1,720	↑	2,250	↑	4,400	7/32"	7,400	5/16"	15,000	↑	1,200	↑	2,250	7/32"	7,400	5/16"	15,000
550	↑	—	↑	1,760	↑	2,350	3/16"	4,500	↑	5,500	↑	13,500	↑	1,250	↑	2,350	↑	5,500	↑	13,500
600	↑	—	7/64"	1,800	↑	2,400	↑	3,350	↑	5,700	9/32"	14,000	↑	1,300	↑	2,400	↑	5,700	9/32"	14,000
650	↑	—	↑	—	1/8"	2,500	5/32"	3,500	3/16"	5,900	1/4"	11,000	↑	800	↑	2,450	↑	5,800	↑	11,000
700	↑	—	↑	—	↑	—	↑	—	↑	—	↑	—	↑	840	↑	2,500	↑	5,900	1/4"	11,200
800	↑	—	↑	—	↑	—	↑	—	↑	—	↑	—	↑	880	↑	2,600	3/16"	6,100	↑	9,000
900	↑	—	↑	—	↑	—	↑	—	↑	—	↑	—	↑	920	↑	2,700	↑	4,500	↑	9,400
950	↑	—	↑	—	↑	—	↑	—	↑	—	↑	—	↑	940	1/8"	2,750	↑	4,600	↑	9,600
1,000	↑	—	↑	—	↑	—	↑	—	↑	—	↑	—	↑	960	5/64"	2,800	5/32"	4,700	7/32"	9,800

* Model 421 #38 Orifice maximum differential pressure is 560 psi.

Capacities given are continuous discharge capacities in pounds of hot condensate per hour at pressure differential indicated. For complete trap capacities, refer to page 12.

Table 10-2. Series 5000 and 6000 Traps

Diff. Press., psi	Orifice Size	Model 5133G 5133G-FW	Orifice Size	Model 5155G 5155G-FW	Orifice Size	Model 6155G 6155G-FW
800	5/32"	3,700	↑	4,400	—	—
900	↑	2,700	↑	4,500	—	—
1,000	↑	2,770	↑	4,700	—	—
1,100	↑	2,840	↑	4,900	—	—
1,200	1/8"	2,900	↑	5,000	—	—
1,300	↑	2,100	↑	5,100	—	—
1,350	↑	2,150	5/32"	5,150	—	—
1,400	↑	2,200	↑	3,600	—	—
1,500	7/64"	2,300	↑	3,750	—	—
1,600	↑	—	↑	3,875	—	—
1,700	↑	—	↑	4,000	—	—
1,800	↑	—	1/8"	4,100	—	—
2,000	↑	—	↑	—	5/32"	6,500
2,500	↑	—	↑	—	1/8"	4,700
2,700	↑	—	↑	—	7/64"	3,700

Table 10-3. Pressure-Temperature Rating of Forged Steel Traps

Model No.	Max. Oper. Pressure, psi, Sat. St.	Maximum Allowable Pressure (Vessel Design), psig, of Pressure-Containing Parts at Indicated Temp. °F.							
		-20/+650	700	750	800	850	900	950	1,000
310	400	770	770	730	600				
312	600	600	600	560	500				
313	650	1,080	1,080	970	780				
314	650	1,130	1,120	990	810				
315	650	1,015	965	860	690				
316	650	1,100	1,050	940	760				
411G/421	1,000	1,000	1,000	950	840				
413	1,000	1,200	1,200	1,200	1,200	1,050	780		
415	1,000	1,100	1,100	1,100	1,100	1,080	965		
416	1,000	1,700	1,700	1,700	1,660	1,350	990		
5133G	1,500	2,120	2,120	2,120	2,120	1,990	1,730	1,350	930
5155G	1,800	2,520	2,520	2,520	2,520	2,370	2,070	1,610	1,110
6155G	2,700	3,500	3,500	3,500	3,500	3,090	2,410	1,650	

NOTES:

1. Maximum operating pressure to be marked on nameplate will be determined by actual orifice used.
2. Maximum allowable pressures shown in boldface will be marked on nameplate, unless otherwise requested. Traps with flanges may have different pressure-temperature ratings.

List of Materials

Table 10-4. Series 300, 400, 5000 and 6000 Traps

Name of Part	Material	Name of Part	Material
Cap & Body Forgings		Valve Seat	Stainless Steel
No. 310-316	ASTM A 105	Valve	Stainless Steel
No. 411G, 421*	ASTM A 105	Valve Retainer	Stainless Steel
No. 413-416	ASTM A 182 F 22	Lever	Stainless Steel
No. 5133G, 5155G, & 6155G	ASTM A 182 F 22	Guide Pin Assembly	Stainless Steel
Inlet Tube	Steel Pipe	Bucket	Stainless Steel Cap and Tube, Cast Iron Weight No. 5133G, 5155G and 6155G bucket weights. Type 316 SS
Gasket**	Compressed Non-asbestos	421 Pipe Plug	Stainless Steel
Bolts	ASTM A 193 Grade B7		
Nuts	ASTM A 194 Grade 2H		

* 421 Cap ASTM A216 WCB

** Spiral wound stainless steel non-asbestos in 5133G, 5155G, 6155G, 5133G-FW, 5155G-FW, 6155G-FW, 411G, 411G-FW, 421, 421-FW.

though several smaller traps are capable of handling the working pressure.

For superheat service:

1. Don't oversize the orifice; a restricted orifice may be advisable.
2. Specify a burnished valve and seat and also an extended inlet tube and check valve.

3. Provide a drip leg of adequate diameter and length.
4. Provide a generous length (2-3 ft) of inlet piping, with the trap below the main.
5. Don't insulate the trap or the inlet piping.



Options

Table 11-1. Flanged Connections

Flanged traps are furnished with the following ANSI B 16.5 flanges as standard. Flange facings comply with ANSI B16.5.

Pressure Class Rating	Inlet Connection	Outlet Connection
150 and 300	1/16" Raised Face	1/16" Raised Face
600 and Higher	1/4" Raised Face	1/4" Raised Face

Other types of flanged connections (such as large male and female, ring joint, large or small tongue and groove, etc.) can be furnished. Flange requirements for both inlet and outlet must be specified.

Internal Check Valves are spring loaded stainless steel and screw into an extended inlet tube having a pipe coupling at the top to save fittings, labor and money. Internal check valves may result in slightly reduced capacities.

Screwed and Socketweld Connections are available in all sizes for pressures of 900 psi or less.

Traps for pressures of 1500 psi or higher are available with socketweld connections.

Cast 316 Stainless Steel Bodies and all stainless steel internals are available on Models 312, 313, 316, 413 and 415 traps.

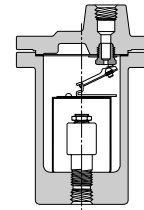

Figure 11-1.
Series 300 - 400 Traps with internal check valve

Physical Data

Table 11-2. Series 300, 400, 5000 and 6000 Traps

Add suffix "CV" to trap number for internal check valve

Model No. SCREWED or SW Model No. FLANGED	310 310FW	312 312FW	313 313FW	314 314FW	315 315FW	316 316FW	411G 411G-FW	413 413FW	415 415FW	416 416FW	421 421FW	5133G 5133G-FW	5155G 5155G-FW	6155G 6155G-FW
Pipe Connections	1/2", 3/4"	1/2", 3/4", 1"	1/2", 3/4", 1"	1", 1 1/4"	1", 1 1/4", 1 1/2"	1 1/2", 2"	1/2", 3/4"	1/2", 3/4", 1"	1", 1 1/4", 1 1/2"	1 1/2", 2"	1/2", 3/4"	1/2", 3/4", 1"	3/4", 1", 1 1/4"	1", 1 1/4"
"A" (Diameter) (in)	4 7/8	6 3/4	8	8 5/8	9 3/4	11 7/8	6 5/16	8 5/8	10 3/4	12 1/2	8	8 1/2	10 3/8	11 3/4
"B" (Height, Screwed or SW) (in)	7 15/16	10 3/16	11 1/2	13 11/16	15	17 7/8	8 13/16	12 3/16	14 15/16	17 5/8	10 9/64	14 1/4	16 1/4	24 1/8
"BB" (in)	12 1/16*	12 5/16	13 7/8	16 1/16	17 9/16	19 11/16	13 15/16*	14 7/8	18 1/16	21 1/2	11 3/4*	16 7/8*	19 15/16*	28 1/2*
"G" (Body OD) (in)	3 1/16	4 3/4	5 1/8	5 3/4	6 5/8	8 3/8	4 1/16	5 3/8	6 7/8	8 1/2	3 7/8	5 3/4	7 5/8	8 3/8
"K" (Ø Outlet to Ø Inlet) (in)	9/16	1 1/4	1 7/16	1 7/16	1 3/4	2 1/8	3/4	1 7/16	1 3/4	2 1/8	—	1 5/16	1 3/4	1 3/4
Number of Bolts	6	6	8	8	9	10	8	8	9	12	8	8	10	10
Weight Scr. or SW (lbs)	10	30	50	70	98	179	25	65	126	205	27 1/2	113	171	325
Weight, Flanged (lbs)	12	32	51	73	103	184	35	70	132	211	36	120	185	340

*"BB" dimensions shown are for 3/4" conn., Class 900 flanged No. 411G-FW; 3/4" conn., Class 600 flanged No. 310FW; 1" conn., Class 1500 flanged No. 5133G-FW; 1 1/4" conn., Class 1500 flanged No. 5155G-FW; and 1 1/4" conn., Class 2500 flanged No. 6155G-FW traps. Consult factory for dimensions of models with other connection sizes and/or flanges.

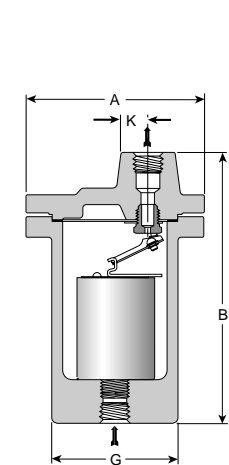

Figure 11-2.
Series 300 - 400 Traps

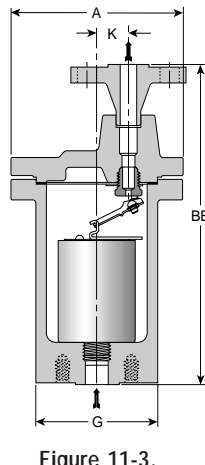

Figure 11-3.
Series 300 FW - 400 FW Traps

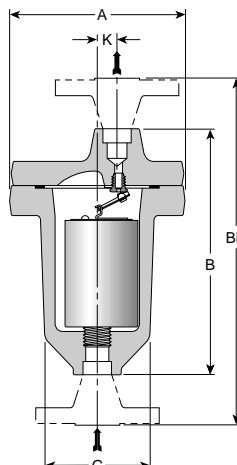

Figure 11-4.
Model 411 Trap

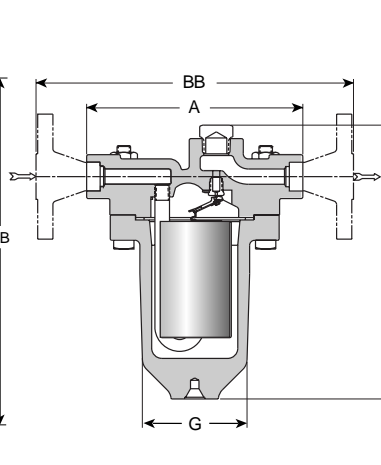

Figure 11-5.
Model 421 Trap

Table 11-3. Socketweld Dimensions

Pipe Size	S-2	S-4 Min.
1/2"	.855	3/8"
3/4"	1.065	1/2"
1"	1.330	1/2"
1 1/4"	1.675	1/2"
1 1/2"	1.915	1/2"
2"	2.406	5/8"
2 1/2"	2.906	5/8"
3"	3.535	5/8"

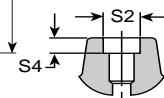
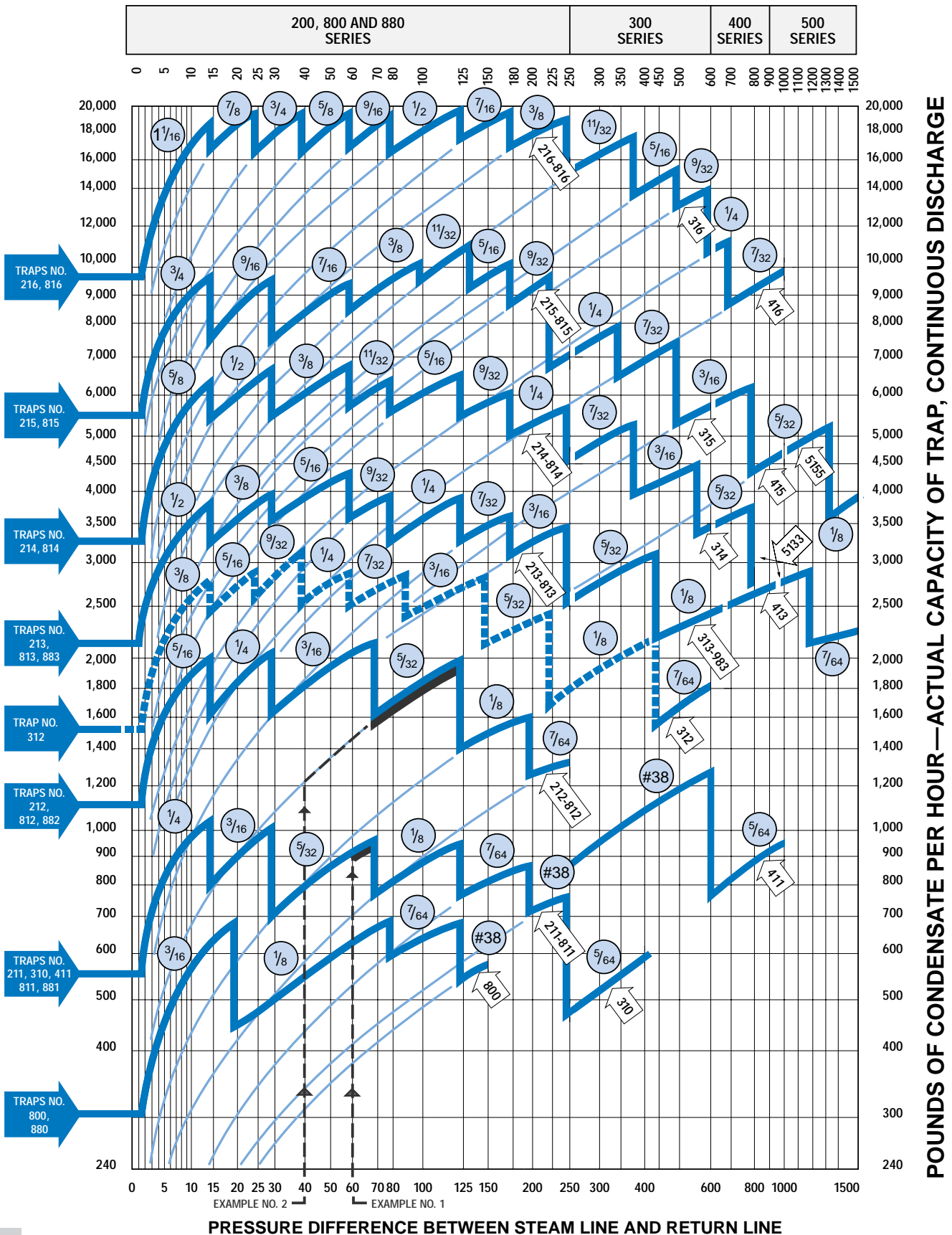

Figure 11-6.
Socketweld Connection

All dimensions and weights are approximate. Use certified print for exact dimensions.

Inverted Bucket Trap Capacity Chart



POUNDS OF CONDENSATE PER HOUR—ACTUAL CAPACITY OF TRAP, CONTINUOUS DISCHARGE

How to Use the Inverted Bucket Trap Capacity Chart

This catalog should be utilized as a guide for the installation and operation of steam trapping equipment by experienced personnel. Selection or installation should always be accompanied by competent technical assistance or advice. Armstrong and its local representatives are available for consultation and technical assistance. We encourage you to contact your Armstrong representative for complete details.

To select an inverted bucket steam trap using the Armstrong capacity chart, you must know the condensate load, safety factor and pressure differential. Remember, the objective is always to select a trap that can 1) operate at the maximum differential pressure and 2) handle the capacity at the minimum differential pressure. Consider the following typical problems.

EXAMPLE 1. Constant Pressure and Condensing Rate

Given:
 Maximum pressure differential _____ 70 psi
 Operating differential _____ 60 psi
 Condensate load 300 lbs/hr
 times 3:1 safety factor or _____ 900 lbs/hr

Enter chart at 60 psi line and go up to 900 lbs/hr capacity. This is directly on the $\frac{5}{32}$ " orifice line as shown in Fig.13-1. The capacity of this $\frac{5}{32}$ " orifice at pressures less than 30 psi is indicated by the thin blue line. Follow the line to the right to the vertical drop at 70 psi. This means this orifice will operate to a maximum of 70 psi differential—the other requirement for this application. Follow the heavy line back to the left and note that it's attached to the arrow indicating that the 211, 811 or 881 traps with the $\frac{5}{32}$ " orifice will yield this capacity. This is the trap to use.

Figure 13-1.

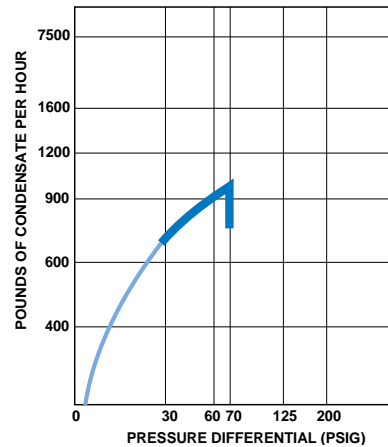

EXAMPLE 2. Constant Pressure and Condensing Rate but with Possible High Back Pressure

Assume for example:
 Maximum pressure differential _____ 90 psi
 Operating differential minimum _____ 40 psi
 Operating differential normally _____ 60 psi
 Condensate load 300 lbs/hr
 times 3:1 safety factor or _____ 900 lbs/hr

Note in Fig.13-1 that the $\frac{5}{32}$ " orifice will handle the 900 lbs/hr load at a differential pressure of 60 psi. When the operating differential drops to the minimum level (40 psi), however, the capacity is only 800 lbs/hr.

To solve the problem, refer to the sawtooth chart. Enter at the minimum differential pressure (40 psi) and move up until you intersect a line that is above 900 lbs/hr capacity, which is the first thin blue line above the heavy blue "sawtooth" for the 211, 811 and 881 traps. Note that this is the continuation of the capacity line for the $\frac{5}{32}$ " orifice for the 212, 812 and 882 traps. Now follow the line to the right until the vertical drop at 125 psi differential. This is within our requirement of 90 psi. Therefore a $\frac{5}{32}$ " orifice can handle the 900 lbs/hr condensate load when fitted into a 212, 812 or 882 trap and that it will not lock shut at the 90 psi maximum differential. This is the trap to use since it will handle the load at both the minimum and maximum operating differentials, even though it has a maximum operating pressure differential of 125 psi.

How the Capacity Chart Was Made

The Armstrong capacity chart shows continuous discharge capacities of Armstrong traps under actual operating conditions as determined by literally hundreds of tests. In these tests condensate at the steam temperature corresponding to the test pressure was used. The choking effect of flash steam through the orifice, as well as the back pressure created by flash steam, were automatically taken into account. Actual installation hookups were used so that pipe friction in both inlet and discharge lines also were reflected in the results.

Trap capacity ratings based on cold water tests which produce no flash

steam would be much too high. Orifice tests also are too high because they ignore pipe friction. Theoretical calculations of trap capacities have never been conservative. You can depend on Armstrong capacity ratings because they show actual capacities of hot condensate.

Heavy blue "sawtooth" curves show capacities for traps using maximum possible diameter orifices for the pressures shown.

Thin line curves extending down to the left of the heavy curves show the capacities of Armstrong traps at pressures below their maximum ratings. For example: A No. 216 trap, with $\frac{1}{2}$ " orifice good for a maximum working pressure of 125 psi,

will have a continuous discharge capacity of a little less than 12,000 lbs/hr at 40 psi.

Close study of this chart reveals that steam trap capacity is governed by more than just the orifice diameter. A 2" No. 216 trap with $\frac{1}{2}$ " discharge orifice, working at 15 psi pressure, has a continuous discharge capacity of some 7,200 lbs/hr, but a $\frac{3}{4}$ " No. 213, also with $\frac{1}{2}$ " orifice and also working at 15 psi pressure, has a continuous discharge capacity of only 3,900 lbs/hr. In the case of the No. 213, friction in the $\frac{3}{4}$ " pipe is greatly restricting capacity, whereas there is little capacity loss due to pipe friction when a $\frac{1}{2}$ " orifice is used in a 2" pipe at 15 psi.

Series 2010 Stainless Steel Traps

For pressures to 400 psig...capacities to 860 lbs/hr

With the Series 2010's 360° universal connector, you can install inverted bucket efficiency and long service life in *any* piping configuration with little or no repiping. You get the reliability of the inverted bucket operating principle. Plus all the benefits of all-stainless steel construction:

- A sealed, tamperproof package
- A compact, lightweight trap

- The ability to withstand freezeups without damage
- Exceptional corrosion resistance
- A three-year guarantee against defective materials, workmanship or wear

Series 2010 steam traps combine savings in three important areas: energy, installation and replacement. The 360° universal connector

provides quick, easy in-line renewability along with all the proven advantages of an inverted bucket operation. Choice of NPT or BSPT screwed connections, or socketweld connections.

Also available with optional integral strainer (IS Connector), with either 1/2" SW or 3/8" NPT blowdown.

Capacities

Table 14-1. Series 2010 Traps

Differential Pressure, psi	Orifice Size	Model 2010	Orifice Size	Model 2011
5		85		390
10		120		460
15		140		510
20		160		575
25		185		615
30		200		630
40		230		700
50		250		740
60		270		740
70		300	5/32"	830
80		325		750
100		370	1/8"	800
125		400		730
150		450	7/64"	800
200	#38	505	#38	740
250		—		680
300		—		680
400		—	5/64"	760

Capacities given are continuous discharge capacities in pounds of hot condensate per hour at pressure differential indicated.

Figure 14-1. Model 2010

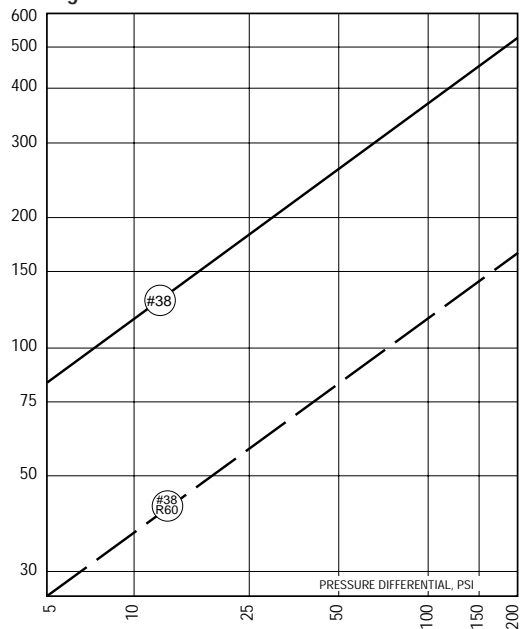

*NOTE: Because the orifice is located at the top, inverted bucket steam traps handle dirt and scale better than other types of traps. However, in applications where extremely dirty conditions exist, care should be exercised in the use of all types of restricted-orifice, reduced-capacity traps.

List of Materials

Table 14-2. Series 2010 Traps

Name of Part	Material	Name of Part	Material
Body	304-L Stainless Steel	Retaining Ring	Carbon Steel
Connections	304 Stainless Steel	Flange	Carbon Steel
Valve Seat	Stainless Steel	Flange Retainer	304 Stainless Steel
Valve	Stainless Steel	Trap Mounting Bolts	ASTM A193 GR. B-7
Valve Retainer	Stainless Steel	2010 IS Connector	
Lever	Stainless Steel	Connector Body (IS)	316 Stainless Steel
Guide Pin Assembly	Stainless Steel	Screen	304 SS 20 X 20 Mesh
Bucket	Stainless Steel	Screen Retainer	316 Stainless Steel
Connector Body	304 Stainless Steel	Retainer Gasket	304 SS Non-asbestos
Connector Gasket	304 SS Non-asbestos	Retainer Bolts	ASTM A193, GR. B-7

Figure 14-2. Model 2011

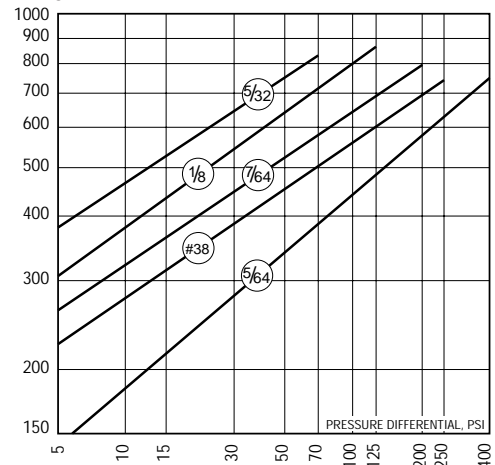



Physical Data

Table 15-1. Series 2010 Traps

Model No.	2010	2011
Pipe Connections	1/2", 3/4"	1/2", 3/4"
"A" (Diameter) (in)	2 ^{11/16}	2 ^{11/16}
"B" (Height) (in)	6	6 ^{15/16}
"C" (Face to Face) (in)	2 ^{3/8}	2 ^{3/8}
"CC" (Face to Face) (in)	4 ^{19/32}	4 ^{19/32}
"D" (Bottom to ϕ) (in)	4 ^{19/32}	5 ^{9/16}
"E" (ϕ to Outside) (in)	4 ^{9/16}	4 ^{9/16}
"F" (ϕ to Bolt) (in)	1	1
"FF" (ϕ to Retainer) (in)	3	3
Weight (lbs)	4 ^{1/4}	4 ^{1/2}
Weight with IS Connector (in)	7	7 ^{1/4}
Maximum Allowable Pressure (Vessel Design)	400 psig @ 800°F	400 psig @ 800°F
Max. Operating Pressure (psi)	200	400

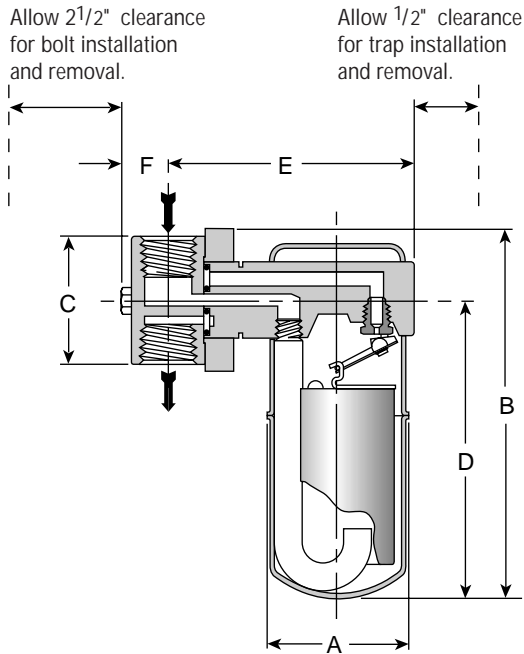

Figure 15-1. Model 2011 Trap

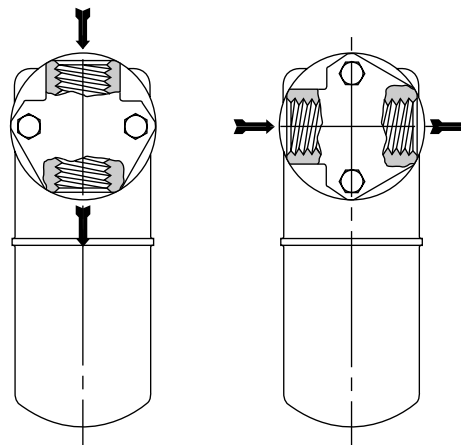

Figure 15-2. Model 2011 Trap

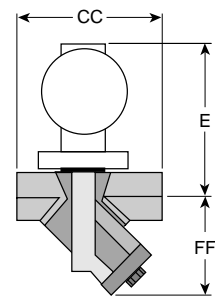

Figure 15-3. Model 2011 with 2010 IS Connector.

All dimensions and weights are approximate. Use certified print for exact dimensions.

Series 1810 Stainless Steel Traps

For pressures to 650 psig...capacities to 2,380 lbs/hr

A quick and easy "in-line" replacement for other types of side inlet/side outlet traps, the Series 1810 brings together all the benefits of energy-efficient inverted bucket operation. Side inlet/side outlet convenience plus lightweight construction mean an inverted bucket trap that will operate efficiently on

applications such as tracer lines, drips, heating, processing and similar applications. Choice of NPT or BSPT screwed connections, or socketweld.

With the 1810 Series, you get all-stainless steel construction with its three-year guarantee. Plus all the

benefits of inverted bucket operation:

- A long, trouble-free service life
- Excellent purging action
- Continuous air venting
- And the ease and flexibility of in-line installation

Capacities

Table 16-1. Series 1810 Traps

Differential Pressure, psi	Orifice Size	Model 1810	Orifice Size	Model 1811	Orifice Size	Model 1812
1/4	↑	15	↑	380	↑	320
1/2	↑	25	↑	430	↑	420
1	↑	35	↑	510	↑	570
5	↑	85	↑	790	↑	1,000
10	↑	120	↑	950	↑	1,400
15	↑	140	*1/4"	1,040	↑	1,625
20	↑	160	↑	880	↑	1,800
25	↑	185	*3/16"	950	↑	1,950
30	↑	200	↑	840	1/4"	2,260
40	↑	230	↑	850	↑	1,950
50	↑	250	↑	900	3/16"	2,090
60	↑	270	*5/32"	950	↑	2,230
70	↑	300	↑	780	5/32"	2,380
80	↑	325	*1/8"	950	↑	1,830
100	↑	370	↑	800	7/64"	2,000
125	↑	400	7/64"	890	↑	1,340
150	↑	450	↑	750	1/8"	1,760
200	#38	505	#38	550	7/64"	1,450
250	↑	—	5/64"	580	↑	1,200
300	↑	—	—	—	↑	1,260
400	↑	—	—	—	↑	1,350
450	↑	—	—	—	↑	1,425
500	↑	—	—	—	↑	1,475
550	↑	—	—	—	↑	950
600	↑	—	—	—	#38	1,475
650	↑	—	—	—	5/64"	950

Figure 16-1. Model 1810

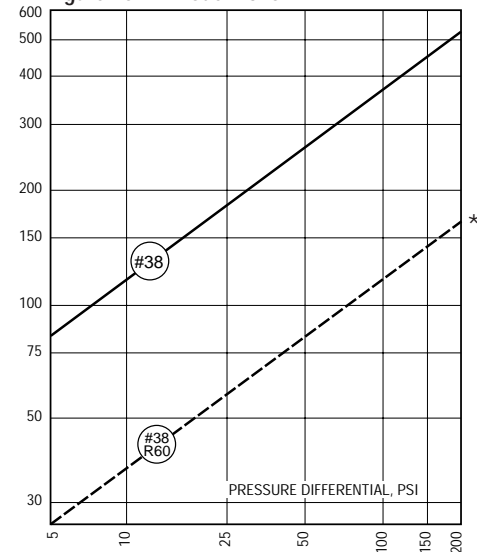

*NOTE: Because the orifice is located at the top, inverted bucket steam traps handle dirt and scale better than other types of traps. However, in applications where extremely dirty conditions exist, care should be exercised in the use of all types of restricted-orifice, reduced-capacity traps.

Capacities given are continuous discharge capacities in pounds of hot condensate per hour at pressure differential indicated.
*Orifices available only with 3/4" connections.

Figure 16-2. Model 1811

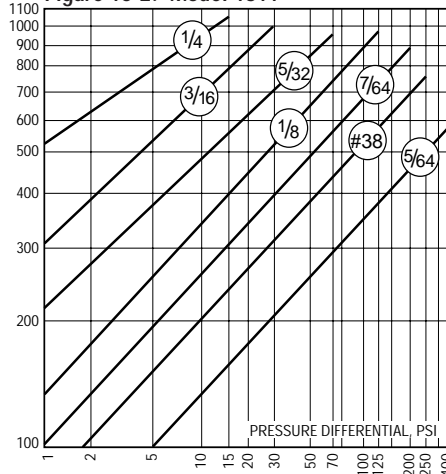
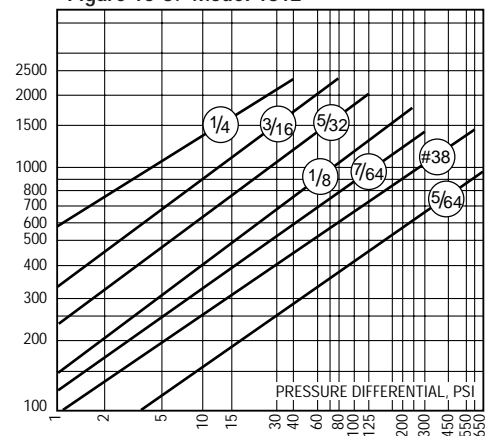

Figure 16-3. Model 1812





Physical Data

Table 17-1. Series 1810 Traps

Model No.	1810	1811	1812	
Pipe Connections	3/8", 1/2"	1/2"	3/4"	3/4", 1"
"A" (Diameter) (in)	2 ^{11/16}	2 ^{11/16}	2 ^{11/16}	4
"B" (Height) (in)	5 ^{5/16}	6 ^{5/16}	6 ^{9/16}	9
"C" (Face-to-Face) (in)	4 ^{5/16}	4 ^{5/16}	4 ^{5/16}	4 ^{9/16}
"D" (Bottom to \bar{C} Inlet) (in)	4 ^{7/16}	5 ^{7/16}	5 ^{9/16}	8 ^{1/8}
Weight (lbs)	1 ^{3/4}	2	2 ^{3/8}	6 ^{3/4}
Maximum Allowable Pressure (Vessel Design)	400 psig @800°F	400 psig @800°F	400 psig @800°F	650 psig @600°F
Maximum Operating Pressure (psi)	200	400	400	650

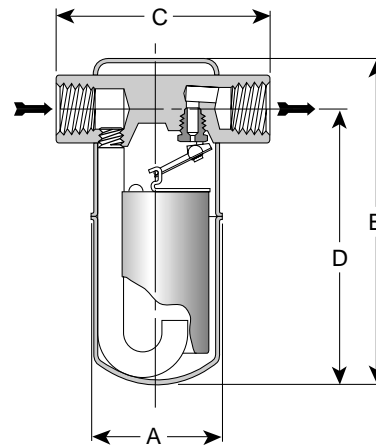

Figure 17-1.
Model 1811 Trap

List of Materials

Table 17-2. Series 1810 Traps

Name of Part	Material
Body	304-L Stainless Steel
Connections	304 Stainless Steel
Valve Seat	Stainless Steel
Valve	Stainless Steel
Valve Retainer	Stainless Steel
Lever	Stainless Steel
Guide Pin Assembly	Stainless Steel
Bucket	Stainless Steel

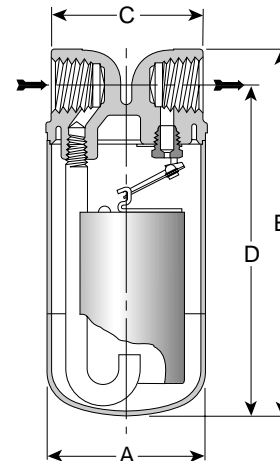

Figure 17-2.
Model 1812 Trap

All dimensions and weights are approximate. Use certified print for exact dimensions.

Series 1010 & U-1010 Stainless Steel Traps

For pressures to 450 psig...capacities to 4,400 lbs/hr

The Series 1010 stainless steel inverted bucket steam trap normally lasts three to four times longer than conventional traps used in identical services. Heat-treated stainless steel valves and seats are of the same design, material and workmanship as those used in traps for pressures up to 900 psi and temperatures to 900°F. More compact than cast iron or stainless steel equivalents, Series 1010 traps are ideal for trapping applications such as tracer lines, steam mains and heating/process applications.

For simple, economical installation, inspection and replacement, Armstrong offers Series U-1010 all-stainless steel inverted bucket traps. All sizes are available with socketweld end connections or with standard NPT or British Standard pipe threads. Series U-1010 traps are also offered with integral carbon steel strainers with .045" perforated stainless steel screens. Both the Series 1010 and U-1010 are guaranteed for three years.

All sizes are available with socketweld end connections or with standard NPT or British Standard pipe threads.

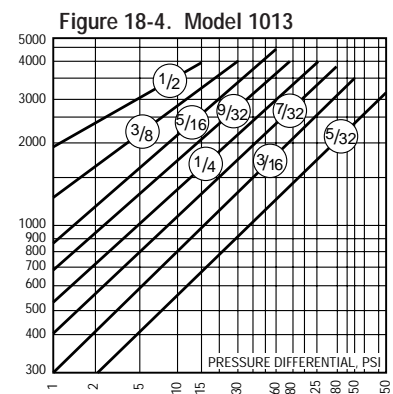
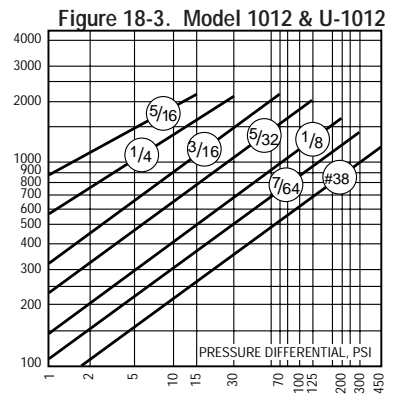
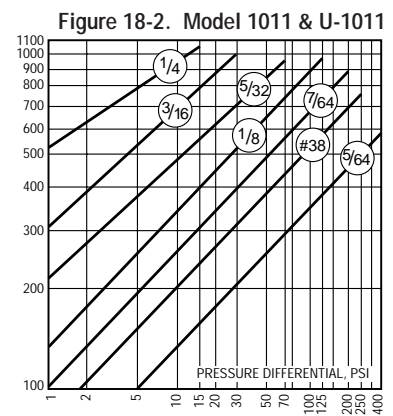
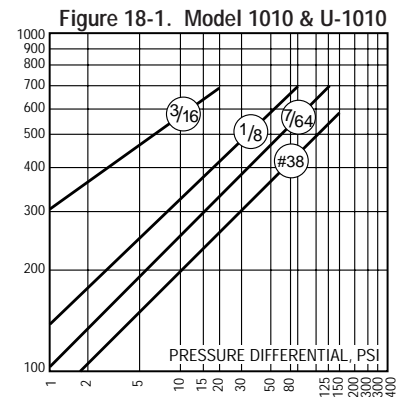

Capacities

Table 18-1. Series 1010 & U-1010 Traps

Differential Pressure, psi	Orifice Size	Model 1010 U-1010	Orifice Size	Model 1011 U-1011	Orifice Size	Model 1012 U-1012	Orifice Size	Model 1013
1/4	↑	139	↑	191	↑	350	↑	950
1/2	↑	200	↑	300	↑	570	↑	1,410
1	↑	270	↑	450	↑	850	↑	1,880
2	↑	340	↑	590	↑	1,140	↑	2,300
5	↑	450	↑	830	↑	1,600	↑	2,900
10	↑	560	↑	950	↑	1,900	↑	3,500
15	↑	640	1/4"	1,060	5/16"	2,100	1/2"	3,900
20	3/16"	680	↑	880	↑	1,800	↑	3,500
25	↑	460	↑	950	↑	1,900	↑	3,800
30	↑	500	3/16"	1,000	1/4"	2,050	3/8"	4,000
40	↑	550	↑	770	↑	1,700	↑	3,800
50	↑	580	↑	840	↑	1,900	↑	4,100
60	↑	635	5/32"	900	↑	2,000	5/16"	4,400
70	↑	660	↑	950	3/16"	2,200	↑	3,800
80	1/8"	690	↑	800	↑	1,650	9/32"	4,000
100	↑	640	↑	860	↑	1,800	↑	3,600
125	7/64"	680	1/8"	950	5/32"	2,000	1/4"	3,900
150	#38	570	↑	810	↑	1,500	↑	3,500
180	—	—	↑	850	↑	1,560	7/32"	3,700
200	—	—	7/64"	860	1/8"	1,600	↑	3,200
250	—	—	#38	760	↑	1,300	3/16"	3,500
300	—	—	↑	510	7/64"	1,400	↑	2,700
400	—	—	5/64"	590	↑	1,120	5/32"	3,100
450	—	—	—	—	#38	1,200	—	3,200

Capacities given are continuous discharge capacities of hot condensate per hour at pressure differential indicated.

List of Materials

Table 19-1. Series 1010 and U-1010 Traps

Name of Part	Series 1010	Series U-1010 Traps
Body	304-L Stainless Steel	304-L Stainless Steel
Connections	304 Stainless Steel	304 Stainless Steel
Valve Seat	Stainless Steel	Stainless Steel
Valve	Stainless Steel	Stainless Steel
Valve Retainer	Stainless Steel	Stainless Steel
Lever	Stainless Steel	Stainless Steel
Guide Pin Assembly	Stainless Steel	Stainless Steel
Bucket*	Stainless Steel	Stainless Steel
Thread Pieces		Carbon Steel
Union Gasket		Spiral Wound Non-asbestos
Strainer Body		Carbon Steel
Screen		.045" Stainless Steel

*Model 1013–Bucket weight of cast iron.



Physical Data

Table 19-2. Series 1010 Traps

Model No.	1010	1011	1012	1013
Pipe Connections	1/2", 3/4"	1/2", 3/4"	3/4"	1"
"A" (Diameter) (in)	2 3/4	2 3/4	3 15/16	4 1/2
"B" (Height) (in)	6 1/16	7 1/4	8 13/16	11 3/4
"K" (C Inlet to C Outlet) (in)	9/16	9/16	7/8	1 3/16
Weight (lbs)	1 1/2	1 3/4	3 1/4	7 1/2
Maximum Allowable Pressure (Vessel Design)	400 psig @ 800°F	400 psig @ 800°F	450 psig @ 800°F	450 psig @ 800°F
Maximum Operating Pressure (psi)	150	400	450	450

NOTE: Model 1013—Only available with screwed connections.

Table 19-3. Series U-1010 Traps

Model No.	U-1010	U-1011	U-1012
Pipe Connections	1/2", 3/4"	1/2", 3/4"	3/4"
"A" (Diameter) (in)	2 3/4	2 3/4	3 15/16
"B" (Height, screwed or SW) (in)	7 15/16	9 1/8	10 15/16
"BB" (Height with Strainer, screwed or SW) (in)	9 1/2	10 11/16	12 1/2
"K" (C Outlet to C Inlet) (in)	9/16	9/16	7/8
"E" (Height, C Inlet to Outlet) (in)	8 5/8	9 13/16	11 5/8
"L" (Inlet to C outlet) (in)	3 1/8	3 1/8	3 1/4
Weight (lbs)	2 1/4	2 1/2	3 3/4
Weight, with Strainer (lbs)	3 1/2	3 3/4	5
Maximum Allowable Pressure (Vessel Design)	400 psig @ 500°F	400 psig @ 500°F	450 psig @ 500°F
Maximum Operating Pressure (psi)	150	400	450

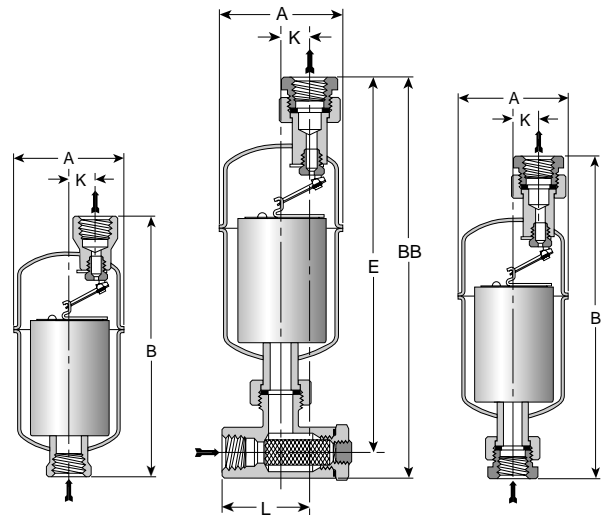

Figure 19-1. Series 1010 Traps

Figure 19-2. Series U-1010 Trap with strainer

Figure 19-3. Series U-1010 Traps

Options

- Stainless Steel Internal Check Valve
- Bucket Vent Wire
- Thermic Vent Bucket, 250 psi maximum
- Socketweld Connections

All dimensions and weights are approximate. Use certified print for exact dimensions.

Cast Steel Inverted Bucket Traps

For pressures to 600 psig...capacities to 4,400 lbs/hr

Armstrong offers two sizes of cast steel traps with in-line horizontal pipe connections and integral strainers. Choice of screwed or socketweld connections or welded-in flanges.

The "sawtooth" curves on Chart 20-1 show actual trap capacities (continuous discharge) using maximum diameter orifices at pressures shown. The dashed extensions to the left

show the capacities of the same orifices at pressures below the maximum for which the trap is usually furnished. Each vertical step in the black curves is at the point beyond which the next smaller size orifice is supplied. The orifice diameters in fractions of inches are shown in the small circles. For detailed instructions, see page 13.

List of Materials

Table 20-1. Series 980 Traps

Name of Part	Material	Name of Part	Material
Cap & Body	ASTMA 216 Grade WCB	Lever	Stainless Steel
Inlet Tube	Steel Pipe	Guide Pin Assembly	Stainless Steel
Gasket	Compressed Non-asbestos	Bucket	Stainless Steel
Bolts	Square Head, ASTMA 193 Grade B7	Integral Strainer	Stainless Steel
Nuts	Hex, Heavy, ASTMA 194 Grade 2H	Screen Retainer	Steel
Valve Seat	Stainless Steel	Retainer Gasket 981	Spiral Wound Stainless Steel and Non-asbestos
Valve	Stainless Steel	Retainer Gasket 983	Compressed Non-asbestos
Valve Retainer	Stainless Steel		

Capacities

Chart 20-1. Series 980 Traps

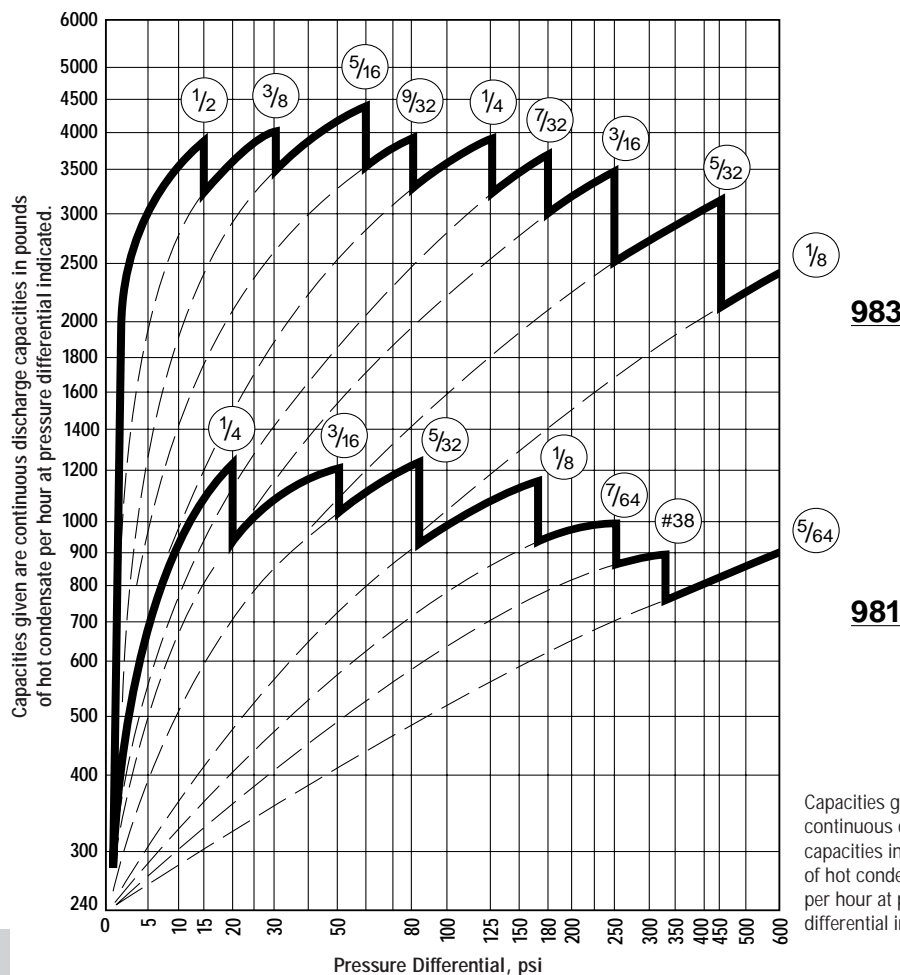

Table 20-2. Series 980 Traps

Differential Pressure, psi	Orifice Size	Model 981	Orifice Size	Model 983
5	↑	730	↑	2,900
10	↑	950	↑	3,500
15	↑	1,120	1/2"	3,900
20	1/4"	1,240	↑	3,500
25	↑	1,030	↑	3,800
30	↑	1,080	3/8"	4,000
40	↑	1,160	↑	3,800
50	3/16"	1,225	↑	4,100
60	↑	1,100	5/16"	4,400
70	↑	1,150	↑	3,800
80	↑	1,200	9/32"	4,000
85	5/32"	1,220	↑	3,550
100	↑	960	↑	3,600
125	↑	1,040	1/4"	3,900
150	↑	1,100	↑	3,500
175	1/8"	1,160	↑	3,650
180	↑	925	7/32"	3,700
200	↑	940	↑	3,200
250	7/64"	975	3/16"	3,500
300	↑	880	↑	2,750
325	#38	890	↑	2,800
350	↑	770	↑	2,875
400	↑	800	↑	3,050
450	↑	830	5/32"	3,150
500	↑	850	↑	2,250
550	↑	875	↑	2,325
600	5/64"	900	1/8"	2,425



Physical Data

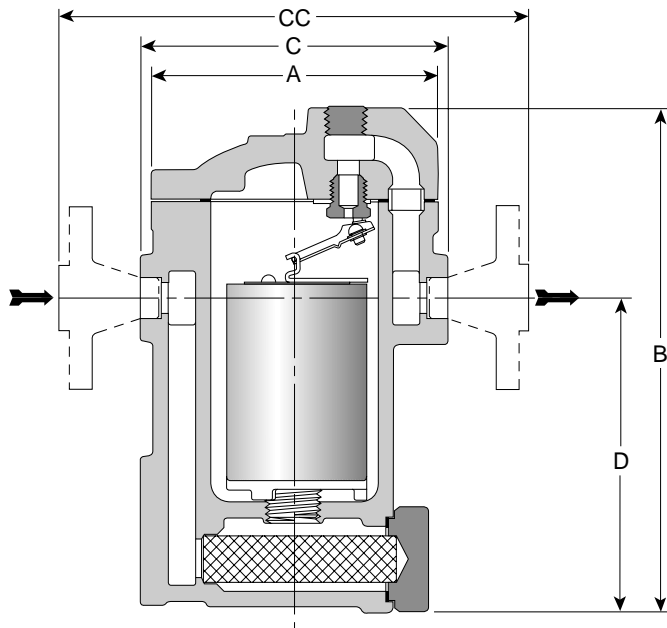

Figure 21-1.
Series 980 Cast Steel Traps

Table 21-1. Series 980 Traps

Model No.	981	983
Pipe Connections	1/2", 3/4"	3/4", 1"
Test Plug (in)	1/2	3/4
"A" (Flange Diameter) (in)	4 1/2	7 1/4
"B" (Height) (in)	8 5/8	12 5/16
"C" (Face-to-Face, Scr or SW) (in)	5 3/8	7 3/4
"CC" (Face-to-Face, Class 600 ANSI flanges*) (in)		
1/2" connection	9 1/4	—
3/4" connection	9 3/8	11 3/4
1" connection	—	12 1/8
"D" (Bottom to \varnothing Inlet)	4 13/16	7 9/16
Weight, Scr or SW (lbs)	11 1/2	43
Weight, 600 Class Flanges (lbs) (1/2" conn.)	18	50
Maximum Allowable Pressure (Vessel Design)	600 psig @ 650°F	600 psig @ 650°F
Maximum Operating Pressure (psi)	600	600

*Face-to-face, other flanges on request. Also available with ANSI raised face, flat face, or ring joint flanges.

Automatic Differential Condensate Controllers

For pressures to 250 psig...capacities to 20,000 lbs/hr

Armstrong designed the automatic differential condensate controllers (DC) for applications where condensate must be lifted from a drain point or gravity drainage applications where increased velocity will aid drainage. Lifting from the drain point (syphon drainage) causes a reduction in pressure which flashes a portion of the condensate into steam. Unable to differentiate

between flash steam and live steam, ordinary steam traps close and impede drainage.

Increased velocity with gravity drainage will aid in drawing the condensate and air to the DC. This increased velocity is caused by an internal by-pass, controlled by a manual metering valve, so the condensate controller will automatically vent

the by-pass or secondary steam. This is then directed to the condensate return line or collected for use in other heat exchangers.

Capacity considerations vary greatly with the application, but for most installations, a single DC will provide sufficient capacity.

Capacities

Table 22-1. Series 20 and 80 Differential Condensate Controllers

Differential Pressure, psi	Orifice Size	Model 21-DC 81-DC	Orifice Size	Model 22-DC 82-DC	Orifice Size	Model 23-DC 83-DC	Orifice Size	Model 24-DC 84-DC	Orifice Size	Model 25-DC	Orifice Size	Model 26-DC
1/4	↑	191	↑	350	↑	950	↑	1,400	↑	2,050	↑	4,050
1/2	↑	300	↑	570	↑	1,410	↑	2,160	↑	3,100	↑	6,240
3/4	↑	395	↑	740	↑	1,618	↑	2,600	↑	3,740	↑	7,510
1	↑	450	↑	850	↑	1,880	↑	2,900	↑	4,160	↑	8,400
2	↑	590	↑	1,140	↑	2,300	↑	3,700	↑	5,400	↑	10,700
3	↑	680	↑	1,320	↑	2,600	↑	4,150	↑	6,200	↑	12,000
4	↑	750	↑	1,480	↑	2,780	↑	4,500	↑	6,800	↑	13,000
5	↑	830	↑	1,600	↑	2,900	↑	4,800	↑	7,600	↑	14,500
10	↑	950	↑	1,900	↑	3,500	↑	5,800	↑	9,000	↑	17,300
15	1/4"	1,060	5/16"	2,100	1/2"	3,900	5/8"	6,500	3/4"	10,000	1 1/16"	19,200
20	↑	880	↑	1,800	↑	3,500	↑	6,000	↑	8,500	↑	18,500
25	↑	950	↑	1,900	↑	3,800	↑	6,500	↑	9,200	↑	20,000
30	3/16"	1,000	1/4"	2,050	3/8"	4,000	1/2"	6,800	9/16"	9,800	↑	18,000
40	↑	770	↑	1,700	↑	3,800	↑	5,800	↑	8,300	↑	20,000
50	↑	840	↑	1,900	↑	4,100	↑	6,300	↑	9,000	↑	18,200
60	↑	900	↑	2,000	5/16"	4,400	3/8"	6,800	7/16"	9,500	↑	19,800
70	5/32"	950	3/16"	2,200	↑	3,800	↑	6,000	↑	9,200	↑	18,300
80	↑	800	↑	1,650	9/32"	4,000	1 1/32"	6,400	↑	9,700	↑	19,000
100	↑	860	↑	1,800	↑	3,600	↑	6,200	3/8"	10,400	↑	18,000
125	1/8"	950	5/32"	2,000	1/4"	3,900	5/16"	6,700	↑	10,900	↑	20,000
130	↑	780	↑	1,410	↑	3,300	↑	5,500	1 1/32"	11,000	↑	17,900
150	↑	810	↑	1,500	↑	3,500	↑	5,700	↑	9,500	↑	18,500
180	↑	850	↑	1,560	7/32"	3,700	9/32"	6,000	5/16"	10,000	7/16"	20,000
200	7/64"	860	1/8"	1,600	↑	3,200	↑	5,300	↑	9,200	↑	17,500
225	↑	730	↑	1,280	↑	3,400	↑	5,500	9/32"	9,800	↑	18,500
250	#38	760	7/64"	1,300	3/16"	3,500	1/4"	5,700	1/4"	7,000	3/8"	19,000

Capacities given are continuous discharge capacities in pounds of hot condensate per hour at pressure differential indicated.

List of Materials

Table 22-2. Series 20 and 80 Differential Condensate Controllers

Model No.	Series 20-DC & Series 80-DC
Cap and Body	Cast Iron, ASTM A 48 Class 30
Gasket	Compressed Non-asbestos
Bolting	SAE, Grade 2*
Condensate Valve & Seat	Stainless Steel
Condensate Operating Mechanism	Stainless Steel, Cast Iron Bucket Weight on No. 84, 24, 25 and 26

*No. 81-DC SAE, Grade 5



Table 23-1. Series 20 and 80 Differential Condensate Controllers

Model No.	21-DC	22-DC	23-DC	24-DC	25-DC	26-DC	81-DC	82-DC	83-DC	84-DC
Inlet & Outlet Connections	1/2"	3/4"	1"	1 1/4"	1 1/2"	2"	3/4"	3/4"	1"	1 1/4"
Secondary Steam Conn. (in)	3/8	1/2	1/2	3/4	1	1	3/8	1/2	1/2	3/4
"A" (Diameter) (in)	4 1/4	5 1/4	6 3/8	7 1/2	8 1/2	10 3/16	3 3/4	5 5/8	7	8
"B" (Height) (in)	9 3/4	12 1/4	15 1/2	18	20 1/4	23 1/2	8	10 5/8	13	15
"C" (in)	7 3/4	9 1/2	12 3/4	15	16 3/4	19 3/4	5	6 1/2	7 3/4	9
"L" (in)	14 7/8	18 1/8	21 3/4	23 7/8	26 3/4	31	13 1/4	16 5/8	19	21
Weight (lbs)	7	14	24	38	53	86	7 1/2	17 1/2	30 1/2	47
Maximum Allowable Pressure (Vessel Design)	250 psig @ 450°F	250 psig @ 450°F	250 psig @ 450°F	250 psig @ 450°F	250 psig @ 450°F	250 psig @ 450°F	250 psig @ 450°F	250 psig @ 450°F	250 psig @ 450°F	250 psig @ 450°F
Maximum Operating Pressure (psi)	250	250	250	250	250	250	250	250	250	250

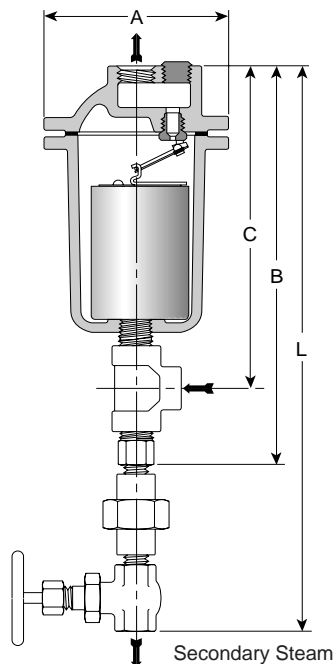

Figure 23-1.
Series 20-DC Traps

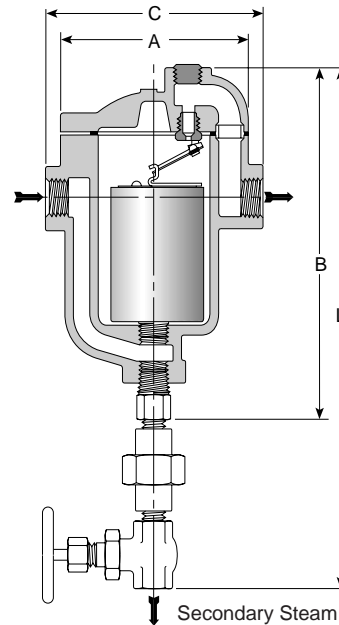

Figure 23-2.
Series 80-DC Traps

All dimensions and weights are approximate. Use certified print for exact dimensions.

The Float & Thermostatic Steam Trap

The More Your Steam Pressure Varies, the More You Need

Armstrong F&T Traps

When steam pressure may vary from maximum steam supply pressure to vacuum, Armstrong F&Ts are your most energy-efficient choice. Our line of F&Ts brings Armstrong performance, dependability and long life to trapping services requiring continuous drainage with high air venting capacity. Thanks to separate orifices for condensate and air, they provide continuous condensate drainage and air venting—even under conditions of zero pressure.

All the benefits detailed on the next page have been designed into Armstrong F&Ts through long experience in the manufacture of pressure float-type drain traps. They assure you of optimum operating efficiency for long periods with minimum trouble.

Built As Tough As the Jobs They Do

Armstrong float and thermostatic traps are unique in their super heavy duty construction. Armstrong uses high quality ASTM A 48 Class 30 cast iron—normally found in pressure vessels rated to 250 psi. Internal mechanisms are made from stainless steel and are heavily reinforced. No brass cotter pins here. Valves and seats are stainless steel, hardened, ground and lapped to withstand the erosive forces of flashing condensate.

Why go to all this trouble on traps normally recommended for low-pressure, modulating service? The answer is in the word *modulating*. Modulating pressures mean widely varying loads, thermal cycling and high air and non-condensable gas loads. In other words, tough service. Inferior, lightweight construction is

a mistake waiting to happen. Trap failures on modulating pressure may lead to water hammer, corrosion and even heat exchanger damage.

Armstrong's published capacities are based on actual measurements of traps handling hot, flashing condensate. Competitive F&Ts may utilize theoretical calculated capacities. Armstrong uses its own steam lab to give you actual capacity—especially important on high-capacity traps such as those in our ultra-capacity line. Not only does Armstrong offer super heavy duty construction for long life and reliability, but we also supply the data to back up performance. Here's a simple, easy-to-remember summary: The more your pressure varies, the more you need Armstrong F&Ts.

Figure 25-1. Armstrong F&T Design

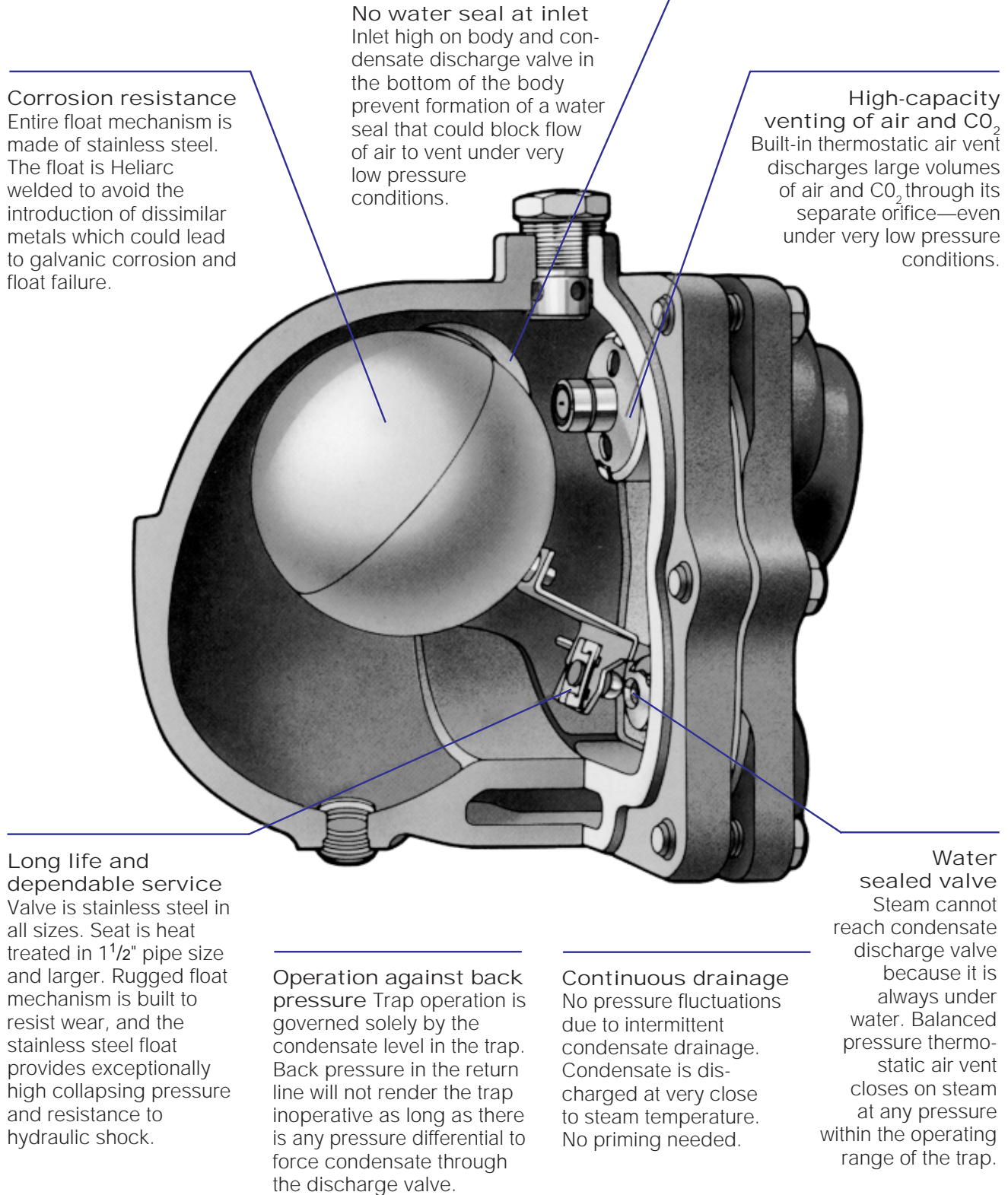

Corrosion resistance
 Entire float mechanism is made of stainless steel. The float is Heliarc welded to avoid the introduction of dissimilar metals which could lead to galvanic corrosion and float failure.

No water seal at inlet
 Inlet high on body and condensate discharge valve in the bottom of the body prevent formation of a water seal that could block flow of air to vent under very low pressure conditions.

High-capacity venting of air and CO₂
 Built-in thermostatic air vent discharges large volumes of air and CO₂ through its separate orifice—even under very low pressure conditions.

Long life and dependable service
 Valve is stainless steel in all sizes. Seat is heat treated in 1 1/2" pipe size and larger. Rugged float mechanism is built to resist wear, and the stainless steel float provides exceptionally high collapsing pressure and resistance to hydraulic shock.

Operation against back pressure
 Trap operation is governed solely by the condensate level in the trap. Back pressure in the return line will not render the trap inoperative as long as there is any pressure differential to force condensate through the discharge valve.

Continuous drainage
 No pressure fluctuations due to intermittent condensate drainage. Condensate is discharged at very close to steam temperature. No priming needed.

Water sealed valve
 Steam cannot reach condensate discharge valve because it is always under water. Balanced pressure thermostatic air vent closes on steam at any pressure within the operating range of the trap.

Series A and B Float & Thermostatic Traps

For pressures from vacuum to 175 psig...capacities to 8,600 lbs/hr

Armstrong Offers Float & Thermostatic Steam Traps in Two Series:

Armstrong "A" Series F&Ts are for industrial service from 0 to 175 psig and feature a balanced pressure phosphor-bronze type bellows caged in stainless steel. Armstrong "A" Series F&T traps are designed for service on heat exchangers

where the pressure fluctuations caused by an intermittent drainer cannot be tolerated and for low to medium pressure steam mains. The "AI" Series features the convenience of in-line connections with the same rugged internals found in the "A" Series.

Armstrong "B" Series traps are for heating service from vacuum to 30 psig and have a balanced pressure

Hastelloy thermostatic wafer. Properly sized, "B" Series F&Ts will drain all the condensate from steam distribution type heat exchangers as fast as it collects—without retarding the flow of air to the trap.

All sizes in both series, except the 3/4" size in the "B" Series, have inlet connections on both sides of the body to provide flexibility in piping.

Capacities

Table 26-1. Series B Traps

Max. Pressure	15 psi (SHEMA Ratings)						15 psi (Actual Ratings)						30 psi						
	1/2"	3/4"	1"	1 1/4"	1 1/2"	2"	1/2"	3/4"	1"	1 1/4"	1 1/2"	2"	1/2"	3/4"	1"	1 1/4"	1 1/2"	2"	
Model No.	15-B2	15-B3	15-B4	15-B5	15-B6	15-B8	15-B2	15-B3	15-B4	15-B5	15-B6	15-B8	30-B2	30-B3	30-B4	30-B5	30-B6	30-B8	
Orifice Size	7/32"	7/32"	5/16"	11/32"	1/2"	7/8"	7/32"	7/32"	5/16"	11/32"	1/2"	7/8"	11/64"	11/64"	1/4"	5/16"	3/8"	9/16"	
Differential Pressure, psi	1/4	70	70	175	425	850	1,775	390	390	500	670	1,480	2,825	350	350	425	635	830	2,250
	1/2	100	100	250	600	1,200	2,500	550	550	700	950	2,100	4,000	500	500	600	900	1,175	3,200
	1	140	140	350	850	1,700	3,550	650	650	950	1,150	2,250	4,900	550	550	750	1,100	1,600	3,600
	2	200	200	500	1,200	2,400	5,000	775	775	1,150	1,350	2,500	6,200	625	625	900	1,225	1,875	4,100
	5	210	210	525	1,260	2,520	5,250	960	960	1,500	1,750	3,100	7,100	775	775	1,250	1,540	2,300	4,900
	10	220	220	550	1,320	2,640	5,500	1,150	1,150	1,850	2,200	3,750	8,150	950	950	1,500	1,900	2,800	5,900
	15	230	230	575	1,380	2,760	5,750	1,230	1,230	2,100	2,500	4,200	8,900	1,100	1,100	1,725	2,150	3,200	6,600
	20	—	—	—	—	—	—	—	—	—	—	—	—	1,220	1,220	1,900	2,380	3,550	7,400
30	—	—	—	—	—	—	—	—	—	—	—	—	1,450	1,450	2,200	2,770	4,050	8,600	

Table 26-2. Series A and AI Traps

Max. Pressure	30 psi						75 psi				125 psi				175 psi						
	1/2"	3/4", 1"	1 1/4"	1 1/2"	2"	1/2"	3/4", 1"	1 1/4"	1 1/2"	2"	1/2"	3/4", 1"	1 1/4"	1 1/2"	2"	1/2"	3/4", 1"	1 1/4"	1 1/2"	2"	
Model No.	30-AI-2	30-A3 30-AI-3 30-A4 30-AI-4	30-A5	30-A6	30-A8	75-AI-2	75-A3 75-AI-3 75-A4 75-AI-4	75-A5	75-A6	75-A8	125-AI-2	125-A3 125-AI-3 125-A4 125-AI-4	125-A5	125-A6	125-A8	175-AI-2	175-A3 175-AI-3 175-A4 175-AI-4	175-A5	175-A6	175-A8	
Orifice Size	1/4"	1/4"	5/16"	3/8"	9/16"	11/64"	11/64"	7/32"	19/64"	3/8"	1/8"	1/8"	11/64"	7/32"	5/16"	7/64"	7/64"	5/32"	13/64"	17/64"	
Differential Pressure, psi	1/4	425	425	635	830	2,250	250	250	370	500	1,000	150	150	250	370	700	50	50	170	250	350
	1/2	600	600	900	1,175	3,200	350	350	500	575	1,250	175	175	350	500	900	65	65	250	325	500
	1	750	750	1,100	1,600	3,600	400	400	600	700	1,750	225	225	400	600	1,100	80	80	300	400	600
	2	900	900	1,225	1,875	4,100	500	500	750	1,000	2,000	300	300	500	750	1,400	100	100	350	500	700
	5	1,250	1,250	1,540	2,300	4,900	640	640	950	1,400	2,800	400	400	700	1,000	2,000	150	150	525	800	1,200
	10	1,500	1,500	1,900	2,800	5,900	825	825	1,200	1,800	3,600	525	525	900	1,400	2,700	280	280	625	1,100	2,100
	20	1,900	1,900	2,380	3,550	7,400	1,100	1,100	1,500	2,430	4,600	700	700	1,150	1,700	3,500	440	440	800	1,375	2,750
	30	2,200	2,200	2,770	4,050	8,600	1,300	1,300	1,750	2,880	5,350	775	775	1,350	2,000	4,200	550	550	900	1,575	3,200
	40	—	—	—	—	—	1,460	1,460	1,960	3,250	6,000	850	850	1,470	2,220	4,550	650	650	1,000	1,740	3,600
	50	—	—	—	—	—	1,600	1,600	2,125	3,550	6,600	950	950	1,650	2,550	5,200	750	750	1,125	1,875	3,950
	60	—	—	—	—	—	1,725	1,725	2,300	3,820	7,100	1,000	1,000	1,780	2,760	5,600	825	825	1,200	2,000	4,300
	75	—	—	—	—	—	1,870	1,870	2,500	4,200	7,650	1,080	1,080	1,950	3,050	6,200	900	900	1,350	2,200	4,750
100	—	—	—	—	—	—	—	—	—	—	1,190	1,190	2,200	3,450	7,100	1,000	1,000	1,525	2,475	5,450	
125	—	—	—	—	—	—	—	—	—	—	1,275	1,275	2,380	3,800	8,000	1,070	1,070	1,700	2,725	6,100	
150	—	—	—	—	—	—	—	—	—	—	—	—	—	—	—	1,110	1,110	1,850	2,950	6,720	
175	—	—	—	—	—	—	—	—	—	—	—	—	—	—	—	1,150	1,150	2,000	3,200	7,300	

NOTE: Cast iron traps should not be used in systems where excessive hydraulic or thermal shock are present. Capacities given are continuous discharge capacities in pounds of hot condensate per hour at pressure differential indicated.



List of Materials

Table 27-1. Series A, AI and B Traps

Name of Part	A, AI Series	B Series
Cap and Body	ASTM A 48 Class 30 Cast Iron	
Bolting	SAE Grade 2	
Gasket	Compressed Non-asbestos	
Valve	440 Stainless Steel	
Valve Seat	303 Stainless Steel* ASTM A 582	
Float	304 Stainless Steel	
Mechanism	Stainless Steel	
Gasket	Compressed Non-asbestos	
Balanced Pressure Thermostatic Air Vent	Stainless Steel and bronze with phosphor bronze bellows, entire unit caged in stainless steel.	Hastelloy Wafer

*440F Stainless Steel in 1 1/2" size and larger.

Options

Integral Vacuum Breaker.

For maximum protection against freezing and water hammer in condensing equipment under modulated control, most authorities recommend the use of a vacuum breaker. Armstrong A, AI & B Series F&T Traps are available with integral vacuum breakers. Maximum service pressure is 150 psig. Suffix the letters VB to model number to specify inclusion of an integral vacuum breaker.

Physical Data

Table 27-2. Series A, AI and B Traps

Trap Series	A Series					AI Series	B Series				
	3/4"	1"	1 1/4"	1 1/2"	2"	1/2", 3/4", 1"	1/2", 3/4"	1"	1 1/4"	1 1/2"	2"
Pipe Connections	3/4"	1"	1 1/4"	1 1/2"	2"	1/2", 3/4", 1"	1/2", 3/4"	1"	1 1/4"	1 1/2"	2"
"B" (Height) (in)	5 1/8	5 1/8	5 13/16	7 7/16	9 3/4	5 1/2	4 1/2	5 1/8	5 3/4	7 7/16	9"
"C" (Face to Face) (in)	4 7/8	4 7/8	4 5/8	5 3/4	7 9/8	5	3 7/8	4 7/8	4 5/8	5 3/4	7 f
"D" (Bottom to \varnothing) (in)	1	1	1 7/32	1 13/32	1 11/16	2 9/16	7/8	1	1 7/32	1 7/16	1"
"H" (Width) (in)	6 7/16	6 7/16	8 1/8	8 7/16	11 5/8	6 1/2	5 3/8	6	7 3/4	8 7/16	11 f
"K" (Connection Offset) (in)	3/8	3/8	—	—	—	—	1/8	3/8	—	—	—
"M" (\varnothing to \varnothing) (in)	3	3	3	4 3/16	6	—	2 3/4	3	3	4 3/16	6
"N" (Top to \varnothing) (in)	3 3/8	3 3/8	3 3/4	3 3/4	5	3 11/16	2 9/16	3	3 3/8	3 3/4	5
Weight (lbs)	9 1/2	8 1/4	11	18 3/4	40	9 3/4	6	8 1/2	11	19	40
Maximum Allowable Pressure (Vessel Design)	175 psig @ 450°F						125 psig @ 450°F	175 psig @ 450°F			
Maximum Operating Pressure (psig)	175 psig, saturated steam						30 psig, saturated steam				

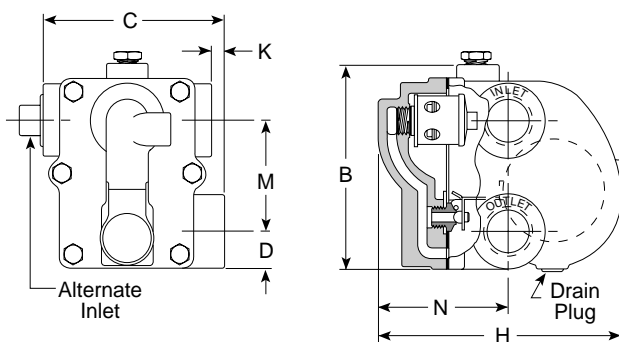

Figure 27-1.

Series A Traps. Series B are similar except for air vent mechanism.

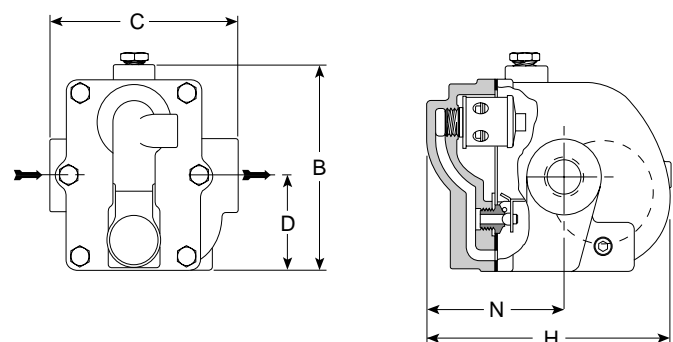

Figure 27-2.

Series AI Traps

All dimensions and weights are approximate. Use certified print for exact dimensions.

Ultra-Capacity Float & Thermostatic Traps

For pressures from 0 to 450 psig...capacities to 280,000 lbs/

Armstrong ultra-capacity F&T steam traps are designed especially to meet very large capacity needs in services where continuous drainage is essential or desirable. These traps are equipped with a balanced pressure phosphor-bronze type air vent caged in stainless steel. Steel bodies

and special high pressure floats enable "LS" and "MS" units to meet more rigid specifications and to be used in hazardous areas.

Ultra-capacity F&Ts are also offered in special purpose configurations. The condensate controller (CC)

configuration was developed for services where condensate must be lifted from the drain point to the trap. Liquid drainer (LD) configurations are for draining large quantities of water and other liquids from air or other gases under pressure.

Capacities

Table 28-1. Series J, K, L, M, LS and MS Traps

Model No.	Single Orifice										Dual Orifice			
	15-J8	30-J8	75-J8	125-J8	175-J8	30-LS10 30-L10	100-LS10 100-L10	150-LS10 150-L10	250-LS10 250-L10	450-LS-LD* 450-LS-CC	50-K10	250-MS12 250-M12	450-MS12-LD* 450-MS12-CC	
Pipe Conn.	2"	2"	2"	2"	2"	2 1/2"	2 1/2"	2 1/2"	2 1/2"	2 1/2"	2 1/2"	3"	3"	
Orifice Size	1 1/16"	3/4"	9/16"	1/2"	7/16"	1 5/8"	1 1/8"	7/8"	1 1/16"	1/2"	1 7/8"	1 7/8"	1 17/32"	
Differential Pressure, psi	1/4	5,585	2,335	2,190	2,120	1,980	11,670	5,975	5,160	4,275	2,760	24,000	24,700	14,850
	1/2	7,900	3,900	3,100	3,000	2,800	16,500	8,450	7,300	6,050	3,900	30,000	35,000	21,000
	2	12,500	7,000	4,900	4,100	3,600	26,000	14,500	12,500	10,500	5,400	42,000	58,000	35,000
	5	17,000	10,900	5,900	4,600	4,200	34,000	20,500	17,000	14,000	7,200	55,000	71,000	42,000
	10	21,600	14,100	10,000	7,100	6,000	40,500	25,000	20,000	17,500	9,000	67,000	82,000	50,000
	15	25,000	16,000	11,400	9,200	7,100	43,500	28,000	22,000	19,000	11,000	74,000	89,000	58,000
	20	—	18,400	12,000	10,500	7,800	46,500	31,500	24,000	20,000	12,500	79,000	96,000	65,000
	30	—	20,000	13,700	11,600	9,500	48,000	35,000	27,500	21,500	14,000	89,000	105,000	72,000
	40	—	—	15,000	12,200	10,300	—	38,500	30,500	23,000	15,000	95,000	116,000	79,000
	50	—	—	16,500	13,100	10,800	—	40,600	33,500	24,000	16,500	105,000	119,000	87,000
	75	—	—	19,700	15,900	12,000	—	46,000	39,000	27,000	20,000	—	133,000	99,000
	100	—	—	—	18,300	14,000	—	50,000	44,000	31,500	23,000	—	145,000	110,000
	125	—	—	—	19,500	15,500	—	—	49,000	34,000	25,500	—	157,000	122,000
	150	—	—	—	—	17,000	—	—	52,000	37,000	27,000	—	168,000	135,000
	175	—	—	—	—	18,000	—	—	—	40,000	28,500	—	179,000	148,000
	200	—	—	—	—	—	—	—	—	43,500	30,000	—	190,000	160,000
	250	—	—	—	—	—	—	—	—	50,000	33,000	—	208,000	185,000
300	—	—	—	—	—	—	—	—	—	35,000	—	—	210,000	
350	—	—	—	—	—	—	—	—	—	37,000	—	—	235,000	
400	—	—	—	—	—	—	—	—	—	38,500	—	—	260,000	
450	—	—	—	—	—	—	—	—	—	40,000	—	—	280,000	
Max. Allow. Pressure (Vessel Design)	J Series = 175 psig @ 450°F LS Series = 450 psig @ 650°F					K Series = 175 psig @ 450°F M Series = 250 psig @ 450°F					L Series = 250 psig @ 450°F MS Series = 450 psig @ 650°F			
Max. Oper. Pressure	15 psig sat. st.	30 psig sat. st.	75 psig sat. st.	125 psig sat. st.	175 psig sat. st.	30 psig sat. st.	100 psig sat. st.	150 psig sat. st.	250 psig sat. st.	450 psig sat. st.	50 psig sat. st.	250 psig sat. st.	450 psig sat. st.	

*Integral thermostatic air vent not supplied above 250 psig. For 250-450 psig operating pressures, use internal venting with CC; or, external back venting is necessary for LD.

NOTE: Cast iron traps should not be used in systems where excessive hydraulic or thermal shock are present.

Capacities given are continuous discharge capacities in pounds of hot condensate per hour at pressure differential indicated.

List of Materials

Table 28-2. Series J, K, L, LS, M and MS Traps

Name of Part	J, K, L, & M Series	LS & MS Series
Cap and Body	ASTM A 48 Class 30 Cast Iron	ASTM A 216 Grade WCB
Cap Extension*	L, LS	304 Stainless Steel, ASTM A 351 Grade CF8
	M, MS	17-4 PH, ASTM A 747 Grade CB7Cu-1
Cap Bolting	ASTM A 193 Grade B7**	ASTM A 193 Grade B7
Cap Gaskets	Compressed Non-asbestos	Compressed Non-asbestos
Valve	Stainless Steel	Stainless Steel
Valve Seat	Stainless Steel	Stainless Steel
Float	304 Stainless Steel	304 Stainless Steel
Mechanism	Stainless Steel	Stainless Steel
Balanced Pressure Thermostatic Air Vent	Stainless Steel and bronze with phosphor bronze bellows, entire unit caged in stainless steel.	Stainless Steel and bronze with phosphor bronze bellows, entire unit caged in stainless steel.

* J Series does not have cap extension.

** J and K Series - ASTM A 307 Grade B.

Options

1. "L", "LS" and "M", "MS" Series available with armored gauge glass which must be specified on original order. Maximum allowable pressure, 250 psig @425°F.
2. All Armstrong F&T traps are available with integral vacuum breakers for service pressures up to 150 psi. Suffix "VB" to model number.
3. "L", "LS" Series traps are available with 2" connections. Specify 30-L8, 30-LS8, 100-L8, 100-LS8, etc.
4. "L", "LS", "M", and "MS" Series available with flanges. Consult factory.
5. "L", "LS", "M", and "MS" Series available with floor mounting bracket. Consult factory.

Installation Notes

Under conditions where the load may approach the maximum capacity of the trap, it is recommended that the size of the discharge line be increased one size as close to the trap cap as is practical.

When "L", "LS", "M", and "MS" Series units are used in severe service conditions or at pressures exceeding 30 psig, use an anchoring bracket or other supportive measures to minimize stress on piping.

Ultra-Capacity "L", "LS", "M", and "MS" Series units **MUST BE WARMED UP** in the proper sequence and gradually. Recommended warm-up rate—not to exceed 100°F/8 minutes.

See your Armstrong Representative.



Physical Data

Table 29-1. Series J, K, L, M, LS and MS Traps

Trap Series	J	K	L & M	LS & MS
"B" (Height) (in)	13 1/16	13 1/16	20 1/4	20
"C" (Width) (in)	9 11/16	9 11/16	14 3/4	15 1/4
"D" (Bottom to ϕ) (in)	2 15/16	2 15/16	4 3/16	4 3/16
"H" (Length) (in)	13 11/16	14 11/16	19 3/4	20 1/4
"M" (ϕ to ϕ) (in)	6 5/8	6 5/8	11 5/16	11 5/16
"P" (Trap top to VB top) (in)	1 13/16	1 13/16	—	—
"S" (Gage Glass Width) (in)	—	—	3 3/4	4 5/8
"T" (Gage Glass Height) (in)	—	—	12	12
Weight (lbs)	80	87	196	290

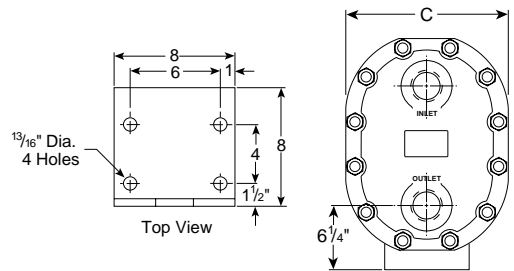

Figure 29-1.
LS and MS Floor Mounting Bracket

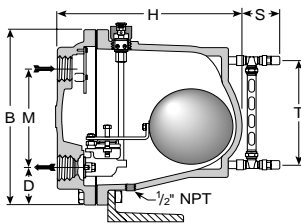

Figure 29-2.
Series L and LS, F&T shown

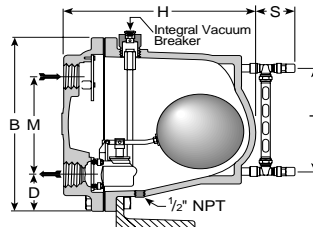

Figure 29-3.
Series M and MS, CC shown

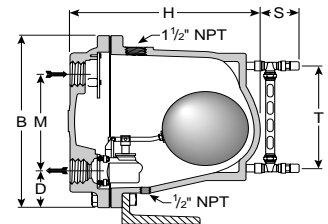

Figure 29-4.
Series M and MS, LD shown

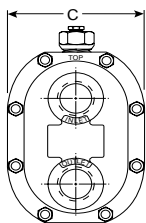

Figure 29-5.
Series J and K Cap

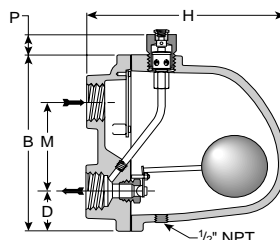

Figure 29-6.
Series J, F&T shown

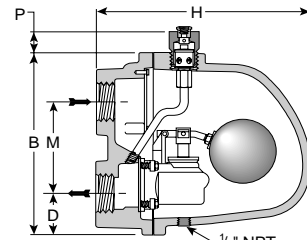

Figure 29-7.
Series K, F&T shown

All dimensions and weights are approximate. Use certified print for exact dimensions.

Thermostatic Wafer Traps

For pressures to 600 psig...start up capacities to 1,600 lbs/hr

Armstrong offers four thermostatic wafer steam traps. The WMT-1 is a stainless steel subcooling trap for instrument tracer line service. Choice of NPT or BSPT screwed connections.

The WT-1 is ideal for low-capacity steam tracers and features an exclusive non-welded wafer design and internal strainer screen two to three times larger than that of other

thermostatic traps. Choice of NPT or BSPT screwed connections.

The WT-2000 does not have a strainer but is equipped with a special connector to expand piping options and simplify installation. Choice of NPT or BSPT screwed connections, or socketweld connections. Also available with optional integral strainer (IS connector).

Armstrong's WT-3 is a carbon steel thermostatic wafer trap for superheated drip service. It features an exclusive non-welded wafer design which eliminates problems associated with weld stress. The WT-3 has no thin-walled enclosures such as bellows or welded diaphragms and is also resistant to water hammer. Choice of NPT or BSPT screwed connections, or socketweld connections.

NOTE: Since the normal operation of all suppressed temperature-discharge (subcooling) steam traps is to back up condensate, they should not be used on drip legs for saturated steam service, heating or process equipment. Exercise care in the maintenance of any thermostatic wafer trap with a small discharge area susceptible to clogging.

Capacities

Table 30-1. Series WT Traps

Differential Pressure,* psi	Model No.				Start Up Cold Water 70° F lbs/hr	Start Up Cold Water 212° F lbs/hr	Operating Condensate 50° F Below Sat. **lbs/hr
	WMT-1	WT-1	WT-2000	WT-3			
5					120	100	10
10					250	170	13
20					320	250	18
30					390	300	20
40					420	350	24
50					490	400	26
75					570	480	30
100					650	580	35
150					700	700	40
200					900	800	46
250	↓				1,000	950	50
300					1,050	1,025	56
350					1,150	1,200	63
400		↓	↓		1,300	1,250	70
500					1,500	1,400	77
600				↓	1,600	1,550	85

*Capacities based on differential pressure with no back pressure.

** Capacities will vary with the degree of subcooling. When greater capacities are required, the trap will automatically adjust to the load, up to the maximum (cold water) capacity shown, by increasing the amount of subcooling.

List of Materials

Table 30-2. Series WT Traps

Name of Part	WMT-1	WT-1	WT-2000	WT-3
Body	304 Stainless Steel	304 Stainless Steel	304 Stainless Steel	Carbon Steel, C-1018
Cap	304 Stainless Steel	304 Stainless Steel	304 Stainless Steel	Carbon Steel, C-1018
Connections	304 Stainless Steel	304 Stainless Steel	—	—
Strainer Screen	—	.027" Perforated Stainless Steel	—	.027" perforated Stainless Steel
Gasket	—	Stainless Steel Clad Non-asbestos	Stainless Steel Clad Non-asbestos	Stainless Steel Clad Non-asbestos
Capsule:				
Wafer	Hastelloy	Hastelloy	Hastelloy	Hastelloy
Body	304 Stainless Steel	303 Stainless Steel	303 Stainless Steel	303 Stainless Steel
Cap	304 Stainless Steel	303 Stainless Steel	303 Stainless Steel	303 Stainless Steel
Connector	—	—	304 Stainless Steel	—
Connector Gasket	—	—	Spiral Wound Stainless Steel Non-asbestos	—
Retaining Ring	—	—	Zinc Plated Carbon Steel	—
Connector Flange	—	—	Nickel Plated Carbon Steel	—
Flange Retainer	—	—	304 Stainless Steel	—



Physical Data

Table 31-1. Series WT Traps

Model No.	WMT-1		WT-1		WT-2000	WT-3
Pipe Connections	1/4", 3/8"	1/2"	1/2"	3/4"	1/2", 3/4"	1/2", 3/4"
"A" (Diameter) (in)	2 1/4	2 1/4	2 1/4	2 1/4	2 1/4	2 1/4
"B" (Height) (in)	3 5/16	3 5/16	4 1/2	4 11/16	5 1/4	4 5/8
"C" (Face to Face) (in)	—	—	—	—	2 3/8	—
"D" (Bottom to ϕ) (in)	—	—	—	—	1	—
Weight (lbs)	5 oz.	7 oz.	1	1 1/4	3 1/4	3
Maximum Allowable Pressure (Vessel Design)	250 psig @ 400°F	250 psig @ 400°F	400 psig @ 650°F	400 psig @ 650°F	400 psig @ 650°F	600 psig @ 750°F
Maximum Operating Pressure (psi)	250	250	400	400	400	600

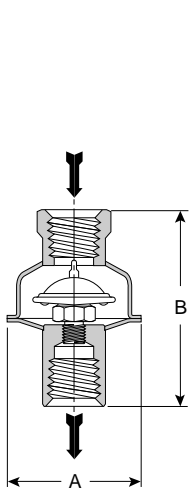

Figure 31-1.
Model WMT-1 Trap

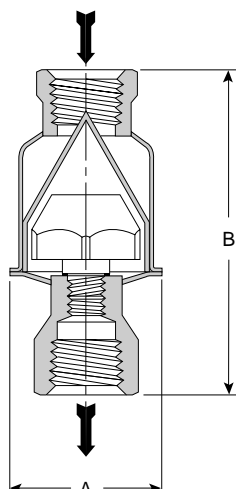

Figure 31-2.
Model WT-1 Trap

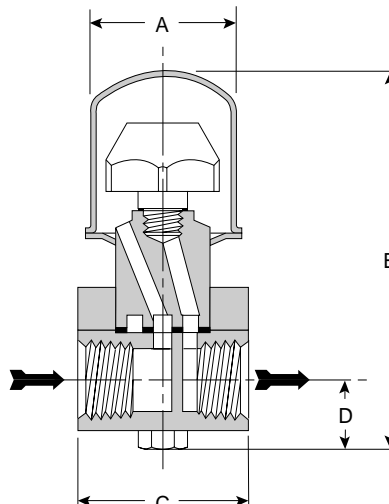

Figure 31-3.
Model WT-2000 Trap

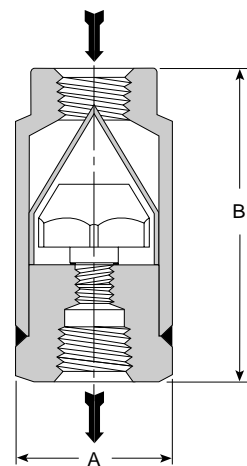

Figure 31-4.
Model WT-3 Trap

All dimensions and weights are approximate. Use certified print for exact dimensions.

Balanced Pressure Bellows Traps

For pressures to 300 psig...capacities to 3,450 lbs/hr

The Armstrong Series TTF are compact and lightweight stainless steel-bodied thermostatic steam traps. They are designed to drain condensate from tracer lines, outdoor steam tank jackets, tank car coils, outdoor steam oil heaters or other applications where resistance to freezing is required. Series TTF traps are offered with 1/2" and 3/4" pipe connections.

- Suitable for pressures from 0 to 300 psig at saturated steam temperature.
- Hot condensate capacities to 3,450 lbs/hr.
- 304-L stainless steel body (connections—304)—sealed, tamperproof.
- Balanced pressure thermostatic element discharges condensate at slightly below steam temperature over the entire pressure range—no adjustments required.

- Phosphor-bronze bellows caged in stainless steel with bronze valve and stainless steel seat.
- Model TTF-1 available with straight-thru or right-angle connections.

NOTE: Suitable for venting air from steam in chamber type heat exchange equipment.



List of Materials

Table 32-1. Series TTF Traps

Name of Part	Material
Body	304-L Stainless Steel
Connections	304 Stainless Steel
Balanced Pressure Thermostatic Air Vent	Stainless Steel and bronze with phosphor-bronze bellows, entire unit caged in stainless steel.
Gasket	Copper clad non-asbestos

Physical Data

Table 32-3. Series TTF Traps

Model No.	Straight-Thru Connections TTF-1		Right-Angle Connections TTF-1R	
	1/2"	3/4"	1/2"	3/4"
Pipe Connections	1/2"	3/4"	1/2"	3/4"
"A" (Diameter) (in)	2 1/4	2 1/4	2 1/4	2 1/4
"B" (Height) (in)	4 1/2	4 11/16	3 3/4	3 15/16
"C" (∅ inlet to face of outlet) (in)	—	—	2 5/8	2 13/16
"D" (∅ outlet to face of inlet) (in)	—	—	1 15/16	1 7/8
"H" (in)	—	—	3 1/16	3
Weight (lbs)	3/4	1	3/4	1
Maximum Allowable Pressure (Vessel Design)	300 psig @ 450°F	300 psig @ 450°F	300 psig @ 450°F	300 psig @ 450°F
Maximum Operating Pressure (psi)	300	300	300	300

Capacities

Table 32-2. Series TTF Traps

Differential Pressure, psi	Orifice Size	Model No. TTF-1 TTF-1R	
5	↑	600	
10		800	
15		1,000	
25		1,300	
50		1,850	
75		2,200	
100		2,400	
125		2,600	
150		2,750	
175		2,900	
200		3,000	
250		3,250	
300		3/16"	3,450

Capacities given are continuous discharge capacities in pounds of hot condensate per hour at pressure differential indicated.

Capacities are based on condensate temperature not to exceed 20°F below steam temperatures.

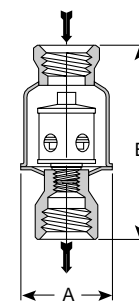

Figure 32-1. TTF-1 Trap

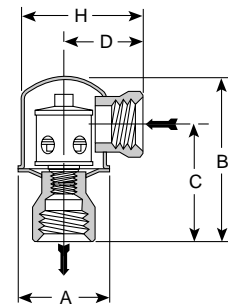

Figure 32-2. TTF-1R Trap

Radiator Traps

For pressures to 65 psig...capacities to 1,600 lbs/hr

Armstrong Series TS radiator traps are offered in both angle and straight patterns. The TS-2 has a balanced pressure thermostatic element with a high quality multiple-convolution bellows. It's ideal for draining equipment such as steam radiators and convectors, small heat exchangers, unit heaters and steam air vents. The TS-2 comes with a strong cast bronze body and a stainless seat. The valve and seat are renewable in-line.



The TS-3 is a heavy duty wafer type trap for the drainage of all types of steam radiators and convectors. Its wafer design is well suited to systems prone to water hammer, which may

damage conventional bellows type units. The TS-3 is repairable in-line and has an all-stainless steel wafer element.

List of Materials

Table 33-1. Series TS Traps

Name of Part	TS-2	TS-3
Cap	Bronze, ASTM B 62	Bronze, ASTM B 62
Body	Bronze, ASTM B 62	Bronze, ASTM B 62
Union Nipple	Brass, ASTM B 584	Brass, ASTM B 584
Valve	Brass	Hastelloy
Valve Seat	Stainless Steel	Stainless Steel
Element	Phosphor-Bronze Bellows	Hastelloy Wafer

Capacities

Table 33-2. Series TS Traps

Differential Pressure, psi	Model No.	
	TS-2	TS-3
1	275	160
3	395	280
5	475	360
10	630	515
20	1,000	625
30	1,200	720
45	1,475	825
50	1,600	870
65	—	960

Capacities given are continuous discharge capacities in pounds of hot condensate per hour at pressure differential indicated.

Physical Data

Table 33-3. Series TS Traps

Model	TS-2				TS-3						
	Angle		Straight		Angle		Straight				
Type	1/2"	3/4"	1/2"	3/4"	1/2"	3/4"	1"	1/2"	3/4"	1"	
Pipe Connections	1/2"	3/4"	1/2"	3/4"	1/2"	3/4"	1"	1/2"	3/4"	1"	
"A" (Diameter) (in)	1 ⁵ / ₈	1 ⁵ / ₈	1 ⁵ / ₈	1 ⁵ / ₈	2	2	2 ³ / ₈	2	2	2 ³ / ₈	
"B" (Height) (in)	2 ¹⁵ / ₁₆	3	2 ¹¹ / ₁₆	2 ⁷ / ₈	2 ⁷ / ₈	3 ⁵ / ₈	3 ⁷ / ₈	2 ⁵ / ₈	3 ³ / ₈	3 ¹ / ₂	
"C" (in)	2 ⁹ / ₁₆	2 ⁷ / ₈	4	4 ¹ / ₂	3 ¹ / ₈	3 ¹ / ₂	4 ¹ / ₈	4 ⁷ / ₈	5 ¹ / ₄	6 ¹ / ₂	
"D" (in)	1 ³ / ₈	1 ⁵ / ₈	1 ¹ / ₈	1 ⁵ / ₁₆	1 ³ / ₈	1 ⁵ / ₈	2	1 ¹ / ₈	1 ³ / ₈	1 ⁵ / ₈	
Weight (lbs)	1 ¹ / ₂	1 ³ / ₄	1 ¹ / ₂	2	1 ¹ / ₂	2	2 ¹ / ₂	1 ¹ / ₂	2 ¹ / ₄	3	
Maximum Allowable Pressure (Vessel Design)	50 psig @ 300°F	50 psig @ 300°F	50 psig @ 300°F	50 psig @ 300°F	65 psig @ 315°F	65 psig @ 315°F	65 psig @ 315°F	65 psig @ 315°F	65 psig @ 315°F	65 psig @ 315°F	
Maximum Operating Pressure (psi)	50	50	50	50	65	65	65	65	65	65	

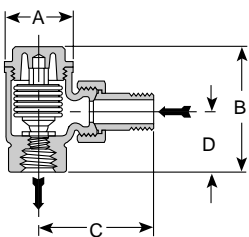

Figure 33-1.
TS-2 Trap Angle Type

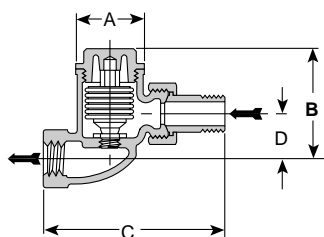

Figure 33-2.
TS-2 Trap Straight Type

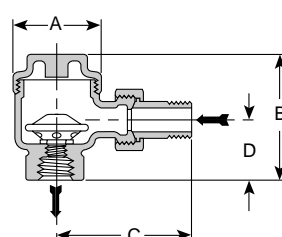

Figure 33-3.
TS-3 Trap Angle Type

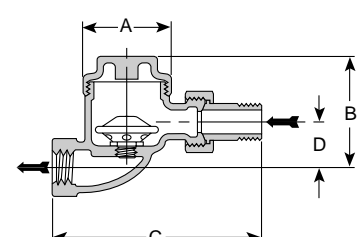

Figure 33-4.
TS-3 Trap Straight Type

All dimensions and weights are approximate. Use certified print for exact dimensions.

Controlled Disc Traps

For pressures to 600 psig...capacities to 2,850 lbs/hr

Armstrong Series CD-40 and CD-60 controlled disc traps both contain a replaceable capsule, making it possible to renew a worn trap by simply replacing the capsule. A heating chamber in the shell assures consistent operation. This steam jacket provides

a relatively constant temperature in the control chamber regardless of ambient conditions. Cycling rate is controlled and does not increase when the trap is exposed to cold winds, rain or snow.

Series CD-60 traps contain integral strainers with ratios of open area to inside area of pipe that equal or exceed those of most separate "Y" type strainers.

List of Materials

Table 34-1. Series CD Traps

Name of Part	CD-40 Series	CD-60 Series
Body	Carbon Steel	Carbon Steel ASTM A 216 Grade WCB
Cap	Carbon Steel	Carbon Steel Forging, ASTM A 105
Strainer Screen	.045" Perforated Stainless Steel	20 x 20 Mesh Stainless Steel
Gasket	—	Compressed Non-asbestos
Bolting	—	Chrome Moly, ASTM A 193 Grade B7
Capsule:		
Controlled Chamber	Hardened Stainless Steel	Hardened Stainless Steel
Controlled Disc	Hardened Stainless Steel	Hardened Stainless Steel
Capsule Body	Hardened Stainless Steel	Hardened Stainless Steel

Capacities

Table 34-2. Series CD Traps

Differential Pressure, psi	Model No.		
	CD-41 CD-61	CD-42 CD-62	CD-43 CD-63
10	250	370	500
25	310	450	610
50	390	570	780
75	450	680	910
100	500	780	1,050
150	600	940	1,290
200	690	1,080	1,500
300	850	1,300	1,860
400	940	1,500	2,160
600	1,185	1,925	2,850

Capacities given are continuous discharge capacities in pounds of hot condensate per hour at pressure differential indicated with condensate temperatures approximately 25°F below steam temperatures.

NOTE: CD traps can operate with a minimum of 2 psi inlet pressure and a maximum of 80% back pressure. However, for best results, inlet pressure should not drop below 10 psi and back pressure should not exceed 50% of inlet pressure.

Physical Data

Table 34-3. Series CD Traps

Model No.	CD-41*		CD-42*	CD-43*	CD-61		CD-62	CD-63
Pipe Connections	3/8"	1/2"	3/4"	1"	3/8"	1/2"	3/4"	1"
"A" (Diameter) (in)	1 1/4	1 1/4	1 5/8	2 3/8	—	—	—	—
"B" (Height) (in)	—	—	—	—	2 5/8	2 5/8	3 7/16	4 1/4
"C" (Length) (in)	3	3 13/32	3 15/16	4 5/8	3 1/2	3 1/2	4 5/8	4 3/4
"D" (∅ to Top of Cap) (in)	—	—	—	—	2	2	2 11/16	3 5/16
Weight (lbs)	3/4	3/4	1 3/4	4 1/4	2 3/4	2 1/2	4 3/4	6 3/4
Max. Allowable Pressure (Vessel Design)	600 psig @ 500°F	600 psig @ 500°F	600 psig @ 500°F	600 psig @ 500°F	600 psig @ 750°F	600 psig @ 750°F	600 psig @ 750°F	600 psig @ 750°F
Minimum Operating Pressure (psi)	10	10	10	10	10	10	10	10
Maximum Operating Pressure (psi)	600	600	600	600	600	600	600	600

*Optional integral strainer available.

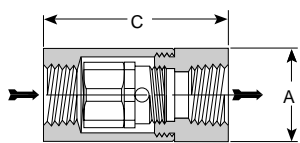

Figure 34-1.
Series CD-40 Traps

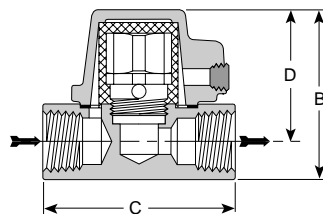

Figure 34-2.
Series CD-60 Traps



Limited Warranty and Remedy

Armstrong International, Inc. warrants to the original user that those products supplied by it and used in the service and in the manner for which they are intended shall be free from defects in materials and workmanship for a period of one (1) year after installation, but not longer than fifteen (15) months from date of shipment or, in the case of stainless steel products (Series numbers: 2010, 1810, 1010), 36 months after installation but not longer than 39 months after date of shipment. Except as may be expressly provided for in a written agreement between Armstrong International, Inc. and the user, which is signed by both parties, Armstrong International, Inc. DOES NOT MAKE ANY OTHER REPRESENTATIONS OR WARRANTIES, EXPRESS OR IMPLIED, INCLUDING, BUT NOT LIMITED TO, ANY IMPLIED WARRANTY OF MERCHANTABILITY OR ANY IMPLIED WARRANTY OF FITNESS FOR A PARTICULAR PURPOSE.

The sole and exclusive remedy with respect to the above limited warranty or with respect to any other claim relating to the products or to defects or any condition or use of the products supplied by Armstrong International, Inc. however caused, and whether such claim is based upon warranty, contract, negligence, strict liability or any other theory, is limited to Armstrong International, Inc.'s repair or replacement of the part or product, excluding any labor or any other cost to remove or install said part or product or, at Armstrong International, Inc.'s option, to repayment of the purchase price. Notice of any such claim must be given in writing to Armstrong International, Inc. within fifteen months (39 months in the case of stainless steel products, as described above) after the first installation or use of the products. In no event shall Armstrong International, Inc. be liable for special, direct, indirect, incidental or consequential damages, including, but not limited to, loss of use or profits or to interruption of business activity.

© 1996 Armstrong International, Inc.

Other Products

Y-Type Strainers

Armstrong Y-type strainers are manufactured in a wide choice of sizes and materials to meet the bulk of all pipeline straining requirements. Request Bulletin No. 171.

Pumping Traps

Armstrong's pumping traps are an ideal non-electric solution for returning condensate in special applications such as evacuating a vacuum, entering a pressurized return line or elevating condensate. Request Bulletin No. 230.

Float Type Drain Traps

The Armstrong float type drain traps are designed for draining liquids from gases under pressure or for discharging water from a light liquid (dual gravity). Capacities to 800,000 lbs/hr. Pressures to 1,800 psig. Request Bulletin No. 402.

Thermostatic Air Vents

Two models available:

- The Model TV-2 is available with straight-through connections, has a cast bronze body and a 125 psig maximum working pressure. Request Bulletin No. 455.
- The Series TTF is available in straight-thru or right angle connections. It features an all-stainless steel body and is suitable for pressure from 0 to 300 psig. Request Bulletin No. 457.

Training for Energy Conservation

Believing that knowledge not shared is energy wasted, Armstrong appreciates the importance of training and offers a wide variety of materials, including a library of more than a dozen educational video tapes. Many training aids are offered free of charge, and others are available at a nominal charge. For a descriptive listing of available training aids, request Bulletin No. 815.

Application assistance is a most important part of the complete service provided by Armstrong International. Armstrong Representatives are qualified by factory training and extensive experience to assist you. Backing the Representatives are Armstrong specialists who are available to assist with especially difficult or unusual requirements.



Armstrong International, Inc.

816 Maple Street, P.O. Box 408, Three Rivers, Michigan 49093 - USA Phone: (616) 273-1415 Fax: (616) 278-6555

Parc Industriel Des Hauts-Sarts, B-4040 Herstal/Liege, Belgium Phone: (04) 2480152 Fax: (04) 2481361

Steam Traps \ Humidifiers \ Steam Coils \ Valves

Metric Tables

Table M8-1. Capacities, Series 800, 880 and 200 Traps

Differential Pressure, BAR	Orifice Size	Model 800	Model 880	Model 811	Model 881	Model 812	Model 882	Model 813	Model 883	Model 814	Model 884	Model 815	Model 885	Model 816	Model 886
0.02	63	63	87	159	432	636	932	1,841							
0.03	91	91	136	259	641	982	1,409	2,836							
0.05	109	109	180	336	735	1,182	1,700	3,414							
0.07	123	123	205	386	855	1,318	1,891	3,818							
0.14	155	155	268	518	1,045	1,682	2,455	4,864							
0.20	177	177	309	600	1,182	1,886	2,818	5,455							
0.30	193	193	341	673	1,264	2,045	3,091	5,909							
0.35	205	205	377	727	1,318	2,182	3,455	6,591							
0.70	255	255	432	864	1,591	2,636	4,091	7,864							
1.00	291	1/4"	482	5/16"	955	1/2"	1,773	2,955	3/4"	4,545	1 1/16"	8,727			
1.40	314	3/16"	400	818	1,591	2,727	3,864	8,409							
1.70	209	432	864	1,727	2,955	4,182	7/8"	9,091							
2.00	227	3/16"	455	1/4"	932	3/8"	1,818	1/2"	3,091	9/16"	4,455	8,182			
2.75	250	350	773	1,727	2,636	3,773	3/4"	9,091							
3.50	264	382	864	1,864	2,864	4,091	8/16"	8,273							
4.00	289	409	909	5/16"	2,000	3/16"	3,091	7/16"	4,318	5/8"	9,000				
5.00	300	5/32"	432	3/16"	1,000	1,727	2,727	4,182	8,318						
5.50	314	364	750	9/32"	1,818	1/32"	2,909	4,409	9/16"	8,636					
7.00	291	391	818	1,636	2,818	4,727	8,182								
8.50	309	1/8"	432	5/32"	909	1/4"	1,773	5/16"	3,045	1/2"	9,091				
9.00	250	355	641	1,500	2,500	1/32"	5,000	8,136							
10.50	259	368	682	1,591	2,591	4,318	8,409								
12.50	—	386	709	7/32"	1,682	9/32"	2,727	5/16"	4,545	7/16"	9,091				
14.00	—	391	1/8"	727	1,455	2,409	4,182	7,955							
15.50	—	332	582	1,545	2,500	9/32"	4,455	8,409							
17.00	—	#38	345	591	3/16"	1,591	1/4"	3,182	3/8"	8,636					

Capacities given are continuous discharge capacities in kilograms of hot condensate per hour at pressure differential indicated.

Table M10-2. Capacities, Series 5000 and 6000 Traps

Differential Pressure, BAR	Orifice Size	Model 5133G-FW	Model 5155G-FW	Model 6155G-FW
55.00	5/32"	1,682	2,000	—
62.00	1,227	2,045	—	
69.00	1,259	2,136	—	
76.00	1,291	2,227	—	
82.75	1/8"	1,318	2,273	—
89.50	955	2,318	—	
93.00	977	2,341	—	
96.50	1,000	1,636	—	
103.50	1,045	1,705	—	
110.50	—	1,761	—	
117.00	—	1,818	—	
124.00	—	1,864	—	
138.00	—	—	5/32"	2,955
172.50	—	—	1/8"	2,136
186.00	—	—	7/64"	1,682

Capacities given are continuous discharge capacities in kilograms of hot condensate per hour at pressure differential indicated.

Table M10-1. Capacities, Series 300 and 400 Traps

Diff. Press., BAR	Orifice Size	Model 310FW	Model 312FW	Model 313FW	Model 314FW	Model 315FW	Model 316FW	Model 411G, 411G-FW, 421, 421FW	Model 413FW	Model 415FW	Model 416FW			
17.00	#38	345	807	3/16"	1,591	2,636	3,182	3/8"	8,636	398	1,591	3,182	3/8"	8,636
21.00	232	864	1,227	2,250	3,409	7,273	432	3/16"	1,227	1/4"	3,409	7,273	3/8"	7,273
24.00	250	909	1,318	2,318	3,636	7,727	455	1,318	3,636	7,727	7,727			
25.50	259	955	1,364	2,409	2,955	4,466	1,364	2,955	4,466	7,818	7,818	1/32"	7,818	
27.50	5/64"	268	1,000	1,409	1,818	3,136	477	1,409	3,136	6,591	6,591			
31.00	—	—	1,091	1,455	1,909	3,227	511	1,455	3,227	—	—			
34.50	—	—	782	1,023	2,000	3,364	545	1,023	3,364	6,818	6,818	5/16"	6,818	
38.00	—	—	800	1,068	2,045	2,500	568	1,068	2,500	6,136	6,136	1/4"	6,136	
41.50	—	—	818	1,091	1,523	2,591	591	1,091	2,591	6,364	6,364	3/8"	6,364	
45.00	—	—	—	1/8"	1,136	5/32"	1,591	3/16"	2,682	—	—	5,000	5,000	
48.50	—	—	—	—	—	—	—	—	—	364	1,114	2,636	5,000	
55.00	—	—	—	—	—	—	—	—	—	382	1,136	2,682	5,091	
62.00	—	—	—	—	—	—	—	—	—	400	1,182	2,773	4,091	
65.50	—	—	—	—	—	—	—	—	—	418	1,227	2,045	4,273	
69.00	—	—	—	—	—	—	—	—	—	427	1,250	2,091	4,364	
										5/64"	436	1,273	2,136	4,455

Capacities given are continuous discharge capacities in kilograms of hot condensate per hour at pressure differential indicated.

All dimensions and weights are approximate. Use certified print for exact dimensions.

Table M9-1. Physical Data, Series 800, Side Inlet, Side Outlet Traps

Add suffix "CV" to trap no. for internal check valve, "T" for thermic vent bucket.

Model No.	800*	811	812	813	814	815	816
Pipe Connections (mm)	15, 20	15, 20, 25	15, 20	20, 25	25, 32	25, 32, 40, 50	50, 65
Test Plug (mm)	6	6	15	20	25	40	50
"A" (Flange Diameter) (mm)	95.2	95.2	143	178	203	229	292
"B" (Height) (mm)	138	175	230	298	346	413	541
"C" (Face-to-Face) (mm)	127	127	165	197	229	260	330
"D" (Bottom to Inlet) (mm)	70	108	137	179	198	205	279
Number of Bolts	6	6	6	6	8	8	8
Weight (kg)	2.3	2.7	6.8	12.5	20.0	32.2	59.4
Maximum Allowable Press. (Vessel Design)	17 BAR @ 232°C	17 BAR @ 232°C	17 BAR @ 232°C	17 BAR @ 232°C	17 BAR @ 232°C	17 BAR @ 232°C	17 BAR @ 232°C
Maximum Operating Press. (BAR)	10.5	17	17	17	17	17	17

* Cannot be furnished with both thermic vent bucket and check valve.

Table M9-2. Physical Data, Series 880, Side Inlet, Side Outlet Traps with Integral Strainers

Add suffix "CV" to trap no. for internal check valve, "T" for thermic vent bucket.

Model No.	880*	881	882	883
Pipe Connections (mm)	15, 20	15, 20, 25	15, 20	20, 25, 32
Test Plug (mm)	6	6	15	20
"A" (Flange Diameter) (mm)	95.2	95.2	142.9	177.8
"B" (Height) (mm)	154	179	244	314
"C" (Face-to-Face) (mm)	127	127	165	200
"D" (Bottom to Inlet) (mm)	87.3	113	146	187
Number of Bolts	6	6	6	6
Weight (kg)	2.5	2.7	7.0	14.1
Maximum Allowable Pressure (Vessel Design)	17 BAR @ 232°C	17 BAR @ 232°C	17 BAR @ 232°C	17 BAR @ 232°C
Maximum Operating Pressure (BAR)	10.5	17	17	17

* Cannot be furnished with both thermic vent bucket and check valve.

Table M9-3. Physical Data, Series 200, Bottom Inlet, Top Outlet Traps

Add suffix "CV" to trap no. for internal check valve, "T" for thermic vent bucket.

Model No.	211	212	213	214	215	216
Pipe Connections (mm)	15	15, 20	15, 20, 25	25, 32	25, 32, 40	40, 50
Test Plug (mm)	3	10	15	15	20	25
"A" (Flange Diameter) (mm)	108	133	162	190	216	259
"B" (Height) (mm)	162	203	273	317	364	432
Number of Bolts	6	8	6	8	8	12
Weight (kg)	2.7	5.2	9.2	15.0	20.3	35.2
Maximum Allowable Pressure (Vessel Design)	17 BAR @ 232°C	17 BAR @ 232°C	17 BAR @ 232°C	17 BAR @ 232°C	17 BAR @ 232°C	17 BAR @ 232°C
Maximum Operating Pressure (BAR)	17	17	17	17	17	17

