

Fisher® 3582 and 3582i Positioners and 582i Electro-Pneumatic Converter

Fisher 3582 pneumatic valve positioners and 3582i electro-pneumatic valve positioners, shown in figure 1, are used with diaphragm-actuated, sliding-stem control valve assemblies. The pneumatic valve positioners receive a pneumatic input signal from a control device and modulate the supply pressure to the control valve actuator, providing an accurate valve stem position that is proportional to the pneumatic input signal.

3582NS positioners are designed for nuclear power applications. The 3582NS construction includes materials that provide superior performance at elevated temperature and radiation levels. The O-rings are EPDM (ethylene propylene) and the diaphragms are EPDM/meta-aramid. EPDM demonstrates superior temperature capability and shelf life over nitrile.

Note

Use a clean, dry, oil-free air supply with instruments containing EPDM components. EPDM is subject to degradation when exposed to petroleum-based lubricants.

The meta-aramid diaphragm fabric demonstrates improved strength retention at elevated temperature and radiation conditions.

Under the 10CFR50, Appendix B, quality assurance program, the 3582NS positioner is qualified commercial grade dedicated. These can be supplied as 10CFR, Part 21 items.

The 3582i electro-pneumatic valve positioner consists of a Fisher 582i electro-pneumatic converter installed on a 3582 pneumatic valve positioner. The 3582i provides an accurate valve stem position that is proportional to a DC current input signal.



FISHER 3582 PNEUMATIC
VALVE POSITIONER

W5498-1

The 582i electro-pneumatic converter, shown in figure 4, is a modular unit that can be installed at the factory or in the field.

The converter receives a DC current input signal and provides a proportional pneumatic output signal through a nozzle/flapper arrangement. The pneumatic output signal provides the input signal to the pneumatic positioner, eliminating the need for a remote mounted transducer.

Note

Upgrading an existing 3582 positioner by field installation of a 582i electro-pneumatic converter may require changing the existing positioner mounting and the input signal range. Contact your Emerson Process Management sales office when planning an upgrade.



Specifications

Note: Specifications for 3582 positioners include 3582A, 3582C, 3582D, 3582G, and 3582NS unless otherwise indicated

Available Configurations

Refer to Type Number Description

Input Signal

3582

■ 0.2 to 1.0 bar (3 to 15 psig), ■ 0.4 to 2.0 bar (6 to 30 psig), or ■ split range, see table 2.

3582i

4-20 mA DC constant current with 30 VDC maximum compliance voltage, can be split range, see table 2.

Equivalent Circuit for 3582i

120 ohms shunted by three 5.6-volt zener diodes, see figure 2

Output Signal

Type: Pneumatic pressure as required by actuator up to 95 percent of maximum supply

Action: Field-reversible between ■ direct and ■ reverse within the pneumatic valve positioner

Supply Pressure⁽¹⁾

Recommended: 0.3 bar (5 psi) above actuator requirement

Maximum: 3.4 bar (50 psig) or pressure rating of actuator, whichever is lower

Supply Medium

Air or natural gas⁽²⁾

The 3582i positioner is not approved for use with natural gas as the supply medium

Maximum Input Bellows Pressure Rating⁽¹⁾

2.4 bar (35 psig)

Maximum Steady-State Air Consumption⁽³⁾

3582:

1.4 bar (20 psig) Supply: 0.38 normal m³/hr (14.0 scfh)

2.0 bar (30 psig) Supply: 0.48 normal m³/hr (18.0 scfh)

2.4 bar (35 psig) Supply: 0.54 normal m³/hr (20.0 scfh)

3582i:

1.4 bar (20 psig) Supply: 0.46 normal m³/hr (17.2 scfh)

2.0 bar (30 psig) Supply: 0.57 normal m³/hr (21.4 scfh)

2.4 bar (35 psig) Supply: 0.64 normal m³/hr (23.8 scfh)

Maximum Supply Air Demand⁽³⁾

1.4 bar (20 psig) Supply: 4.4 normal m³/hr (164.5 scfh)

2.0 bar (30 psig) Supply: 6.7 normal m³/hr (248.5 scfh)

2.4 bar (35 psig) Supply: 7.7 normal m³/hr (285.5 scfh)

Performance

3582

Independent Linearity: ±1 percent of output signal span

Hysteresis: 0.5 percent of span

3582i

Independent Linearity: ±2 percent of output signal span

Hysteresis: 0.6 percent of span

Electromagnetic Compliance for 582i electro-magnetic converter

Meets EN 61326-1 (First Edition)

Immunity—Industrial locations per Table 2 of the EN 61326-1 standard. Performance is shown in table 1 below.

Emissions—Class A

ISM equipment rating: Group 1, Class A

Note: Electromagnetic Compatibility also applies to the 3582i positioner

3582 and 3582i

Open Loop Gain (Output Signal):

■ 100 in the range of 0.2 to 1.0 bar (3 to 15 psig)

■ 55 in the range of 0.4 to 2.0 bar (6 to 30 psig)

Operating Influences

Supply Pressure, For 3582: Valve travel changes less than 1.67 percent per bar (0.25 percent per 2 psi) change in supply pressure

Supply Pressure, For 3582i: Valve travel changes less than 3.62 percent per bar (1.5 percent per 2 psi) change in supply pressure

- continued -

Specifications (Continued)

Operative Temperature Limits⁽¹⁾

Standard Construction

3582 and 3582i -40 to 71°C (-40 to 160°F)
3582NS: -40 to 82°C (-40 to 180°F) with EPDM
elastomers

High-Temperature Construction⁽⁴⁾

3582A and C Only: -18 to 104°C (0 to 220°F) without
gauges

Electrical Classification for 582i

CSA—Intrinsically Safe, Explosion proof, Type n
Dust-Ignition proof, Division 2

FM—Intrinsically Safe, Explosion proof, Type n,
Non-incendive, Dust-Ignition proof

ATEX—Intrinsically Safe & Dust, Type n & Dust,
Flameproof & Dust

IECEx—Intrinsically Safe, Type n, Flameproof (Gas
Atmospheres Only)

Refer to tables 5, 6, 7, and 8 for additional
information

Note: These classifications also apply to the 3582i
positioner

Housing Classification for 582i

CSA—Type 3 Encl.

FM—NEMA 3, IP54

ATEX—IP64

IECEx—IP54

Mount instrument with vent on the side or the
bottom if weatherproofing is a concern.

Note: These classifications also apply to the 3582i
positioner

Other Classifications/Certifications for 582i

INMETRO—Brazil

NEPSI—China

Contact your Emerson Process Management sales
office for classification/certification specific
information

Note: These classifications also apply to the 3582i
positioner

Hazardous Area Classifications for 3582

3582 valve positioners comply with the requirements
of ATEX Group II Category 2 Gas and Dust

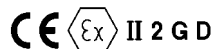

Note: This rating does *not* apply to the 3582i
positioner

Construction Materials

Refer to table 3

Pressure Gauges

40 mm (1.5 inch) diameter with plastic case and brass
connection

- triple scale (PSI, MPa, and bar) or
- dual scale (PSI and kg/cm²)

Pressure Connections

1/4 NPT internal

Electrical Connection for 3582i

1/2-14 NPT conduit connection

Maximum Valve Stem Travel

105 mm (4.125 inches); adjustable to obtain lesser
travel with standard input signal

Characterized Cams

See characterized cams section

Approximate Weight

3582: 2.5 kg (5-1/2 pounds)

3582i: 3.6 kg (8 pounds)

Options

- Instrument, output, and supply pressure gauges;
automotive tire valves; or pipe plugs
(see Type Number Description section)
- Bypass valve (only for direct-acting, 3582
positioners using a full input signal range)
- Characterized cams B and C
- Connectors
for diagnostic testing
- High vibration

NOTE: Specialized instrument terms are defined in ANSI/ISA Standard 51.1 - Process Instrument Terminology.

1. The pressure and temperature limits in this document and any applicable standard or code limitation should not be exceeded.

2. Natural gas should contain no more than 20 ppm of H₂S.

3. Normal m³/hr--normal cubic meters per hour (0°C and 1.01325 bar absolute); Scfh--standard cubic feet per hour (60°F and 14.7 psia).

4. Not available with bypass or pressure gauges.

Table 1. Fisher 582i Electro-Pneumatic Converter⁽¹⁾ EMC Summary Results—Immunity

Port	Phenomenon	Basic Standard	Test Level	Performance Criteria ⁽²⁾
Enclosure	Electrostatic Discharge (ESD)	IEC 61000-4-2	4 kV contact 8 kV air	A
	Radiated EM field	IEC 61000-4-3	80 to 1000 MHz @ 10V/m with 1 kHz AM at 80% 1400 to 2000 MHz @ 3V/m with 1 kHz AM at 80% 2000 to 2700 MHz @ 1V/m with 1 kHz AM at 80%	A
	Rated power frequency magnetic field	IEC 61000-4-8	60 A/m at 50 Hz	A
I/O signal/control	Burst (fast transients)	IEC 61000-4-4	1 kV	A
	Surge	IEC 61000-4-5	1 kV (line to ground only, each)	B
	Conducted RF	IEC 61000-4-6	150 kHz to 80 MHz at 3 Vrms	A

Specification limit = ±1% of span
 1. The information contained in the table also applies to the 3582i positioner.
 2. A = No degradation during testing. B = Temporary degradation during testing, but is self-recovering.

Table 2. Split-Range Capabilities

3582 POSITIONERS				
Split	0.2 to 1.0 Bar or 3 to 15 Psig Input Signal		0.4 to 2.0 Bar or 6 to 30 Psig Input Signal	
	Bar	Psig	Bar	Psig
Two-way	0.2 to 0.6	3 to 9	0.4 to 1.2	6 to 18
	0.6 to 1.0	9 to 15	1.2 to 2.0	18 to 30
Three-way	0.2 to 0.5	3 to 7	0.4 to 0.9	6 to 14
	0.5 to 0.7	7 to 11	0.9 to 1.5	14 to 22
	0.7 to 1.0	11 to 15	1.5 to 2.0	22 to 30

3582i POSITIONER	
Split	4-20 Milliampere Input Signal
Two-way	4 to 12 12 to 20
Three-way	4 to 9.3 9.3 to 14.7 14.7 to 20

Figure 1. Fisher 3582i Electro-Pneumatic Valve Positioner



W8152

Figure 2. Equivalent Circuit

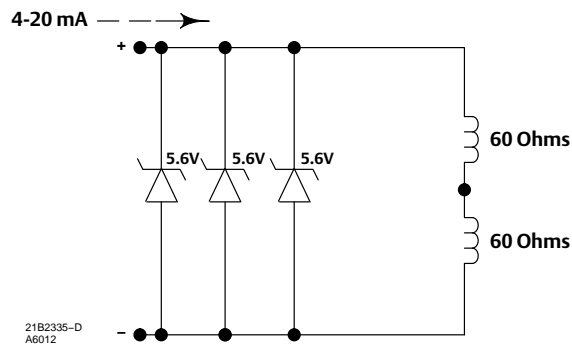

Table 3. Construction Materials

PART	MATERIAL	
	Standard	High-Temperature
Positioner		
Case	Low copper aluminum alloy	---
Cover	Impact-resistant plastic	---
Bellows	Phosphor bronze	---
O-Ring All 3582 except 3582NS 3582NS	Nitrile EPDM	Fluorocarbon ---
Connectors for Diagnostic Testing	Stainless Steel or Brass	---
Relay		
Castings	Aluminum	---
Diaphragms All 3582 except 3582NS 3582NS	Nitrile/Polyester EPDM/meta-aramid	Polyacrylate-Nylon ---
O-Rings All 3582 except 3582NS 3582NS	Nitrile EPDM	Fluorocarbon ---
Gaskets	Nitrile/polyester	Polyacrylate-Nylon
582i Converter		
Case and Cover	Low copper aluminum alloy	---
O-Rings	Nitrile	---

Features

- Versatile Modular Design**—3582 positioners can be upgraded in the field to an electro-pneumatic 3582i by replacing the gauge block with the 582i electro-pneumatic converter (figure 4) assembly. The converter assembly attaches to the positioner case, providing a cost-effective conversion. Thus, in the field, 3582 positioners can be upgraded from pneumatic to electronic to match new control strategies.

Note

Upgrading existing 3582 positioners by field installation of a 582i electro-pneumatic converter may require changing the existing positioner mounting and the input signal range. Contact your Emerson Process Management sales office when planning an upgrade.

Figure 3. Fisher 3582 Pneumatic Valve Positioner Mechanism

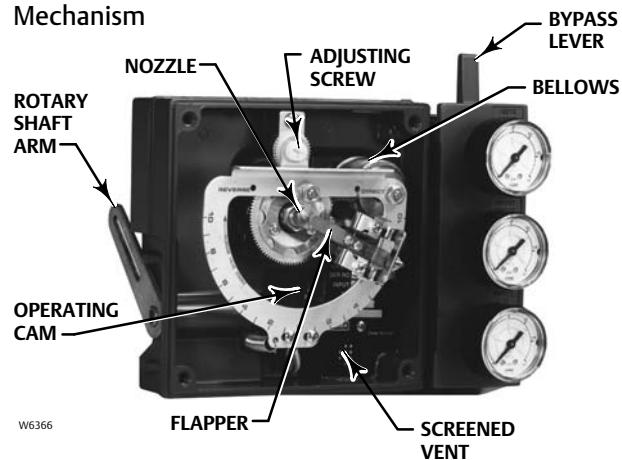

- Accurate, Efficient, Vibration-Resistant Operation**—3582 and 3582i positioners offer a field-proven positioner design which is accurate, fast-responding and able to withstand the vibrations of most plant environments. Low steady-state air consumption contributes to efficient operation.

- **Rangeability**—Both 3582 and 3582i positioners provide split range capabilities. The range of the adjustable zero and span permits the use of all standard input signals including split ranges.
- **Simplified Spare Parts Inventories**—Because units from one positioner family can be used in a variety of control applications, basic spare parts inventory requirements are simplified and fewer spare parts are needed to support a plant-wide positioner applications base.
- **Easy Positioner Adjustments**—With the cover removed, as shown in figure 3, zero and span adjustments are easily accessible and can be made with a screw driver.
- **Stable Operation**—Changes in supply pressure and valve load have minimal effect on positioner operation.
- **Corrosion Resistance**—Case, components, and gasket materials withstand harsh environments. Positioner bleed air purges internal parts for additional protection.
- **Field Reversible**—Simple adjustments permit switching between direct and reverse action.
- **Control Valve Diagnostic Testing Capability**—To support diagnostic testing of valve/actuator/positioner packages with the FlowScanner™ valve diagnostic system, connectors, piping, and other hardware can be installed between the 3582 or 3582i and the actuator.

Type Number Description

3582—Pneumatic valve positioner with bypass and instrument, supply, and output pressure gauges.

3582A—Pneumatic valve positioner without bypass and without pressure gauges.

3582C—Pneumatic valve positioner without bypass and with automotive tire valves instead of pressure gauges.

Figure 4. Fisher 582i Electro-Pneumatic Converter



3582D—Pneumatic valve positioner with bypass and with automotive tire valves instead of pressure gauges.

3582G—Pneumatic valve positioner without bypass and with instrument, supply, and output pressure gauges.

3582NS—Pneumatic valve positioner for nuclear service applications with or without bypass and with automotive tire valves instead of pressure gauges.

3582i—Electro-pneumatic valve positioner without bypass; with 582i converter; and with: ■ supply and output pressure gauges, ■ automotive tire valves, or ■ pipe plugs.

582i—Electro-pneumatic converter with: ■ supply and output pressure gauges, ■ automotive tire valves, or ■ pipe plugs. Used for conversion of a 4-20 milliamperere input signal to a 0.2 to 1.0 bar (3 to 15 psig) input signal for the pneumatic valve positioner.

83L—Pneumatic relay included as part of both 3582 and 3582i positioners.

Principle of Operation

3582 positioners (3582, 3582NS and 3582A, C, D, and G pneumatic valve positioners) accept a pneumatic input signal from a control device. The operational schematic in figure 5 depicts the direct-acting pneumatic valve positioner.

Figure 5. Fisher 3582 Positioner Schematic Diagram

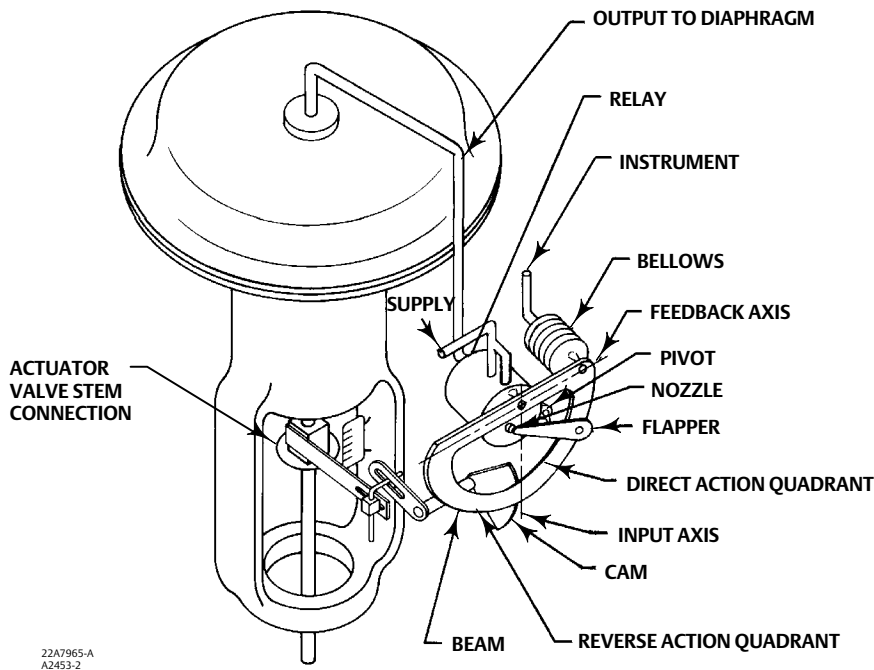

Supply pressure is connected to the 83L relay. A fixed restriction in the relay limits flow to the nozzle so that when the flapper is not restricting the nozzle, air can bleed out faster than it is being supplied.

The input signal from the control device is connected to the bellows. When the input signal increases, the bellows expands and moves the beam. The beam pivots about the input axis moving the flapper closer to the nozzle. The nozzle pressure increases and, through relay action, increases the output pressure to the diaphragm actuator. The increased output pressure to the actuator causes the actuator stem to move downward. Stem movement is fed back to the beam by means of a cam. As the cam rotates, the beam pivots about the feedback axis to move the flapper slightly away from the nozzle. The nozzle pressure decreases and reduces the output pressure to the actuator. Stem movement continues, backing the flapper away from the nozzle, until equilibrium is reached.

When the input signal decreases, the bellows contracts (aided by an internal range spring) and the

beam pivots about the input axis to move the flapper away from the nozzle. Nozzle pressure decreases and the relay permits the release of diaphragm casing pressure to atmosphere. The actuator stem moves upward. Through the cam, stem movement is fed back to the beam to reposition the flapper closer to the nozzle. When equilibrium conditions are obtained, stem movement stops and the flapper is positioned to prevent any further decrease in diaphragm case pressure.

The principle of operation for reverse acting units is similar except that as the input signal increases, the diaphragm casing pressure is decreased. Conversely, a decreasing input signal causes an increase in the pressure to the diaphragm casing.

As shown in figure 6, the 3582i electro-pneumatic positioner accepts a DC current input signal provided to the 582i electro-pneumatic converter attached to the positioner. The 582i provides the pneumatic input signal pressure used by the pneumatic positioner.

Figure 6. Fisher 3582i Positioner Schematic Diagram

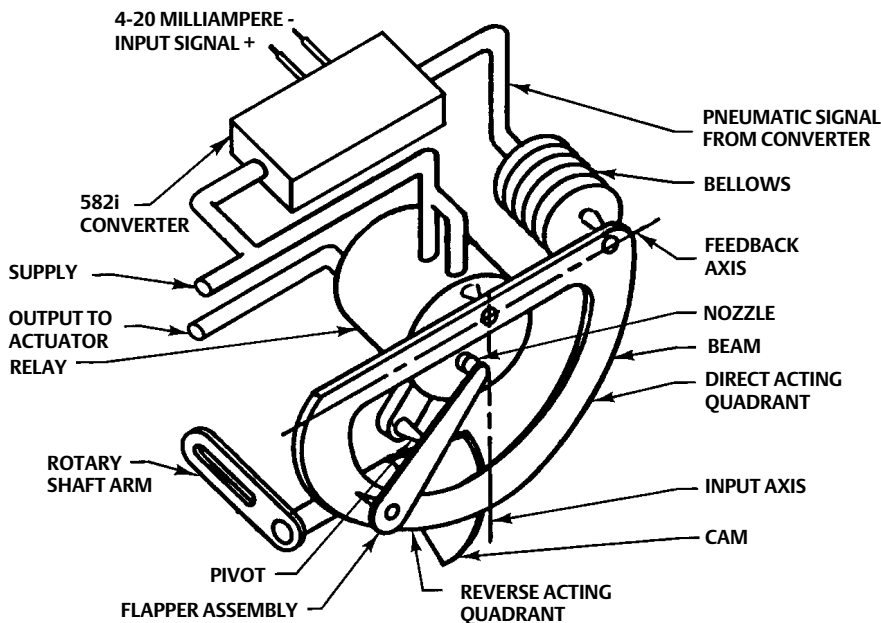

A4818-2

Characterized Cams

Three cams are available for 3582 valve positioners. A linear cam (cam A) is supplied with the unit. Two characterized cams (cams B and C) are available as options. Figure 7 shows the resultant stem travel due to an incremental instrument pressure change for each cam. When the linear cam is the operating cam, there is a linear relationship between an incremental input signal change and valve travel, and the flow characteristic of the valve is that of the control valve. When either characterized cam is the operating cam, the relationship between an incremental input signal change and valve travel changes thereby modifying the valve flow characteristics. Figure 8 shows how the characteristic is modified for an equal percentage valve. Figure 9 shows how the characteristic is modified for a linear valve.

Because 3582 positioners mount the same way on either direct-acting or reverse-acting diaphragm actuators, the cams are reversible.

Figure 7. Instrument Pressure Versus Valve Travel

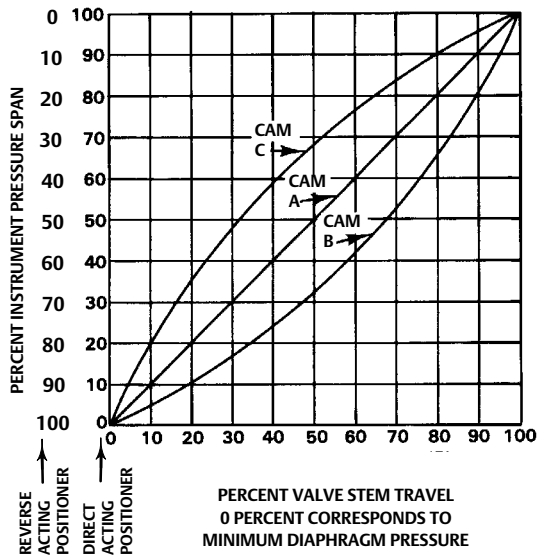

CK4832-A
A1413

Figure 8. Equal Percentage Valve Flow Characteristics as Modified by Various Cams

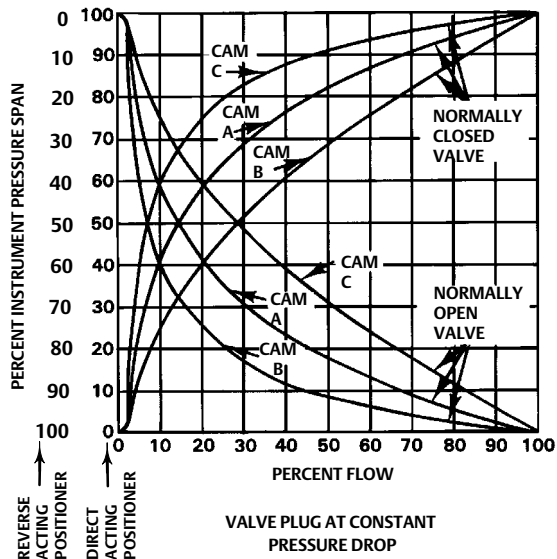

CK4835-A
A1415-1

Figure 9. Linear Valve Flow Characteristics as Modified by Various Cams

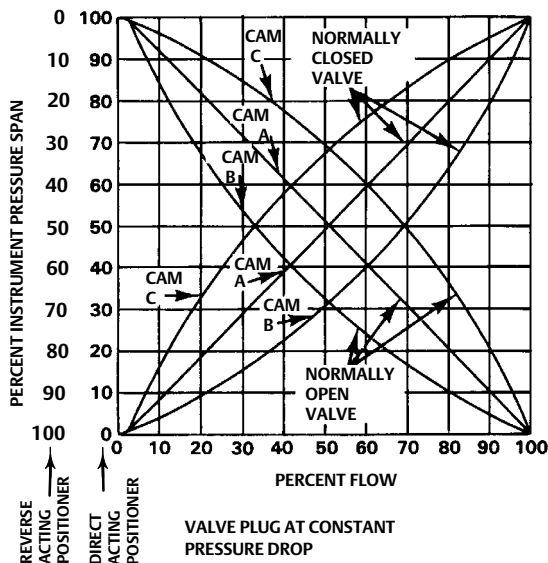

CK4833-A
A1414

Installation

Figure 10 shows a typical positioner mounting for a direct- or reverse-acting actuator. Positioner overall dimensions and connections are shown in figure 10 and table 4.

Ordering Information

When ordering, please specify the product application and construction:

Application

1. Positioner type number. When ordering a 3582i electro-pneumatic positioner, specify: ■ supply and output pressure gauges, ■ automotive tire valves, or ■ pipe plugs.
2. Maximum supply pressure available
3. Direct or reverse acting
4. Valve stroke in inches; actuator type and size
5. Initial cam set-up (cam A, B, or C)
6. Input signal
7. Supply pressure regulator and test pressure gauge.
8. Connectors for diagnostic testing, if required.

Construction

Refer to the specifications. Carefully review each specification; indicate your choice whenever a selection is offered.

Figure 10. Valve Positioner Dimensions and Connections (see table 4 for the X dimension)

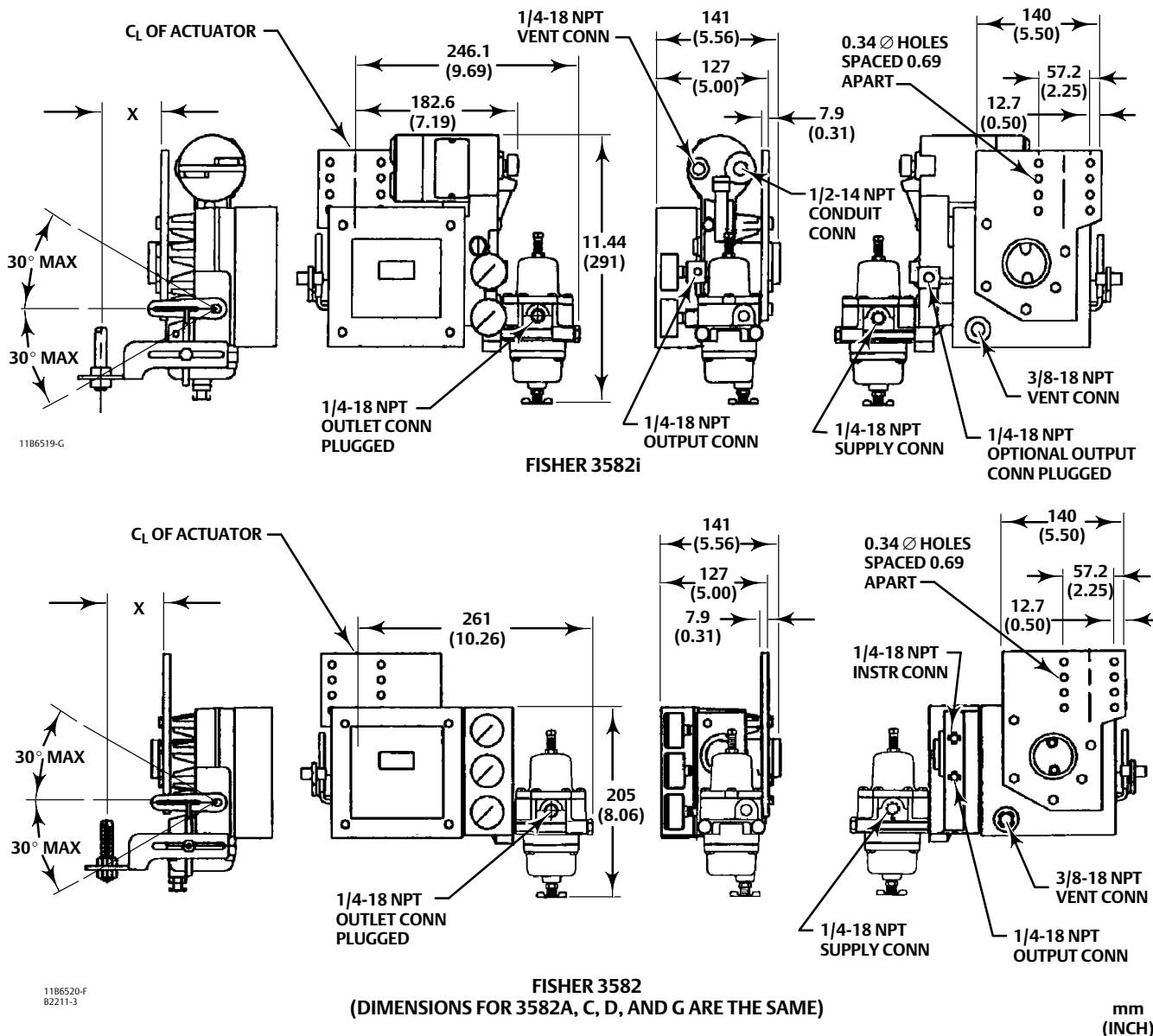

Table 4. Dimensions

STEM TRAVEL		X					
		9.5 mm (0.375 inch) Stem		12.7 mm (0.50 inch) Stem		19.1 mm (0.75 inch) Stem	
mm	Inch	mm	Inch	mm	Inch	mm	Inch
29 or less	1.125 or less	81	3.19	87	3.44	100	3.94
38	1.50	90	3.56	97	3.81	109	4.31
51	2	102	4.00	108	4.25	121	4.75
64	2.50	113	4.44	119	4.69	132	5.19
76	3	124	4.88	130	5.12	143	5.62
89	3.50	135	5.31	141	5.56	154	6.06
102	4	146	5.75	152	6.00	165	6.50

Table 5. Hazardous Area Classifications for Fisher 582i Converter⁽¹⁾—CSA (Canada)

Certification Body	Certification Obtained	Entity Rating	Temperature Code	Enclosure Rating
CSA	Intrinsically Safe Ex ia IIC T4/T5/T6 per drawing GE28591 Ex ia Intrinsically Safe Class I, II Division 1 GP A,B,C,D,E,F,G T4/T5/T6 per drawing GE28591	V _{max} = 30 VDC I _{max} = 150 mA P _i = 1.25 W C _i = 0 nF L _i = 0 mH	T4 (T _{amb} ≤ 71°C) T5 (T _{amb} ≤ 62°C) T6 (T _{amb} ≤ 47°C)	CSA Type 3 Encl.
	Explosion-proof Ex d IIC T6 Class I, Division I, GP A,B,C,D T6	---	T6 (T _{amb} ≤ 71°C)	CSA Type 3 Encl.
	Type n Ex nA IIC T6	---	T6 (T _{amb} ≤ 71°C)	CSA Type 3 Encl.
	Class I, Division 2, GP A,B,C,D T6 Class II, Division 1 GP E,F,G T6 Class II Division 2 GP F,G T6	---	T6 (T _{amb} ≤ 71°C)	CSA Type 3 Encl.

1. These hazardous area classification also apply to 3582i positioners.

Table 6. Hazardous Area Classifications for Fisher 582i Converter⁽¹⁾—FM (United States)

Certification Body	Certification Obtained	Entity Rating	Temperature Code	Enclosure Rating
FM	Intrinsically Safe Class I Zone 0 AEx ia IIC T4/T5/T6 per drawing GE28590 Class I, II, III Division 1 GP A,B,C,D,E,F,G T4/T5/T6 per drawing GE28590	V _{max} = 30 VDC I _{max} = 150 mA P _i = 1.25 W C _i = 0 nF L _i = 0 mH	T4 (T _{amb} ≤ 71°C) T5 (T _{amb} ≤ 62°C) T6 (T _{amb} ≤ 47°C)	NEMA 3, IP54
	Explosion-proof Class I Zone 1 AEx d IIC T6 Class I, Division I, GP A,B,C,D T6	---	T6 (T _{amb} ≤ 71°C)	NEMA 3, IP54
	Type n Class I Zone 2 AEx nA IIC T6	---	T6 (T _{amb} ≤ 71°C)	NEMA 3, IP54
	Class I Division 2, GP A,B,C,D T6 Class II Division 1, GP E,F,G T6 Class II Division 2, GP F,G T6	---	T6 (T _{amb} ≤ 71°C)	NEMA 3, IP54

1. These hazardous area classification also apply to 3582i positioners.

Table 7. Hazardous Area Classifications for Fisher 582i Converter⁽¹⁾—ATEX

Certificate	Certification Obtained	Entity Rating	Temperature Code	Enclosure Rating
ATEX	Ⓔ II 1 G & D			
	Intrinsically Safe Gas Ex ia IIC T4/T5/T6	U _i = 30 VDC I _i = 150 mA P _i = 1.25 W C _i = 0 nF L _i = 0 mH	T4 (T _{amb} ≤ 71°C) T5 (T _{amb} ≤ 62°C) T6 (T _{amb} ≤ 47°C)	IP64
	Dust Ex iaD 20 IP64 T109°C (T _{amb} ≤ 71°C) / T100°C (T _{amb} ≤ 62°C) / T85°C (T _{amb} ≤ 47°C)		---	
	Ⓔ II 2 G & D			
	Flameproof Gas Ex d IIC T6	---	T6 (T _{amb} ≤ 71°C)	IP64
	Dust Ex tD A21 IP64 T74°C (T _{amb} ≤ 71°C)	---		
	Ⓔ II 3 G & D			
Type n Gas Ex nA IIC T6	---	T6 (T _{amb} ≤ 71°C)	IP64	
Dust Ex tD A21 IP64 T74°C (T _{amb} ≤ 71°C)				---

1. These hazardous area classification also apply to 3582i positioners.

Product Bulletin

62.1:3582
May 2012

3582 and 3582i
D200062X012

Table 8. Hazardous Area Classifications for Fisher 582i Converter⁽¹⁾—IECEX

Certificate	Certification Obtained	Entity Rating	Temperature Code	Enclosure Rating
IECEX	Intrinsically Safe Gas Ex ia IIC T4/T5/T6	U _i = 30 VDC I _i = 150 mA P _i = 1.25 W C _i = 0 nF L _i = 0 mH	T4 (T _{amb} ≤ 71°C) T5 (T _{amb} ≤ 62°C) T6 (T _{amb} ≤ 47°C)	IP54
	Flameproof Gas Ex d IIC T6	---	T6 (T _{amb} ≤ 71°C)	IP54
	Type n Gas Ex nA IIC T6	---	T6 (T _{amb} ≤ 71°C)	IP54

1. These hazardous area classification also apply to 3582i positioners.

Neither Emerson, Emerson Process Management, nor any of their affiliated entities assumes responsibility for the selection, use or maintenance of any product. Responsibility for proper selection, use, and maintenance of any product remains solely with the purchaser and end user.

Fisher and FlowScanner are marks owned by one of the companies in the Emerson Process Management business unit of Emerson Electric Co. Emerson Process Management, Emerson, and the Emerson logo are trademarks and service marks of Emerson Electric Co. All other marks are the property of their respective owners.

The contents of this publication are presented for informational purposes only, and while every effort has been made to ensure their accuracy, they are not to be construed as warranties or guarantees, express or implied, regarding the products or services described herein or their use or applicability. All sales are governed by our terms and conditions, which are available upon request. We reserve the right to modify or improve the designs or specifications of such products at any time without notice.

Emerson Process Management
Marshalltown, Iowa 50158 USA
Sorocaba, 18087 Brazil
Chatham, Kent ME4 4QZ UK
Dubai, United Arab Emirates
Singapore 128461 Singapore

www.Fisher.com